

KURKO KOPONEN

NOSTOPALVELUIDEN ASIAANTUNTIJIA



KALUSTOKATALOGI

KOKO MAAN KURKO

NOSTA LUURI, ME NOSTAMME LOPUT

Tarjoamme laadukkaita nostoalan palveluja koko Suomen alueella. Hyvän palvelumme perusta on yli 60 vuoden kokemus, asianmukainen kalusto, huolelliset nostosuunnitelmat sekä osaavat ihmiset. Vuosikymmenten myötä tyytyväiset vakioasiakkaamme ovat kiittäneet toimintavarmuuttamme.

Me palvelemme kaikkia asiakkaitamme isältä pojalle siirtyneen perheyrittäjien tinkimättömyydellä.

Kurko-Koponen Oy:llä on kattava valikoima eri nostototehoisia asennusnosturiautoja, mobiilinnostureita, teollisuusnostureita sekä mininostureita ja niiden lisävarusteita. Lisäksi käytämme yhteistyökumppaneita.

Meiltä saat oikean kaluston, oikeaan aikaan, oikeaan paikkaan.



Yrityksessämme on käytössä sertifoitu laatujärjestelmä ISO 9001/2015, sertifiointin on suorittanut Det Norske Veritas.

Yrityksemme todistukset löytyvät osoitteesta www.tilajavastuu.fi. Kurko-Koponen Oy on INFRA RY:n jäsenyrittäjä. Käytämme nostotöissä Infra Ry:n ajoneuvonostureiden yleisiä vuokrausehtoja.

Lisätietoja: www.infrary.fi.

**Tilaa Kurko-nosturi paikalle:
Puh. 029 170 1400
www.kurkokoponen.fi**

SISÄLLYSLUETTELO

KALUSTOLUETTELO

◆ 215 T/M PERÄASETEINEN PITKÄPUOMINOSTURIAUTO	4
◆ 215 T/M PITKÄPUOMINOSTURIAUTO	5
◇ TUOTEKUVIA	8
◆ 165 T/M PITKÄPUOMINOSTURIAUTO	10
◆ 165 T/M NOSTURIAUTO	14
◆ 165 T/M NOSTURIAUTO	18
◇ TUOTEKUVIA	20
◆ 145 T/M NOSTURIAUTO	22
◆ 135 T/M NOSTURIAUTO	26
◆ 115 T/M NOSTURIAUTO	28
◆ 100 T/M NOSTURIAUTO	32
◇ TUOTEKUVIA	35
◆ 105 T/M NOSTURIAUTO	36
◆ 99 T/M NOSTURIAUTO	38
◇ TUOTEKUVIA	42
◆ 95 T/M NOSTURIAUTO	44
◆ 92 T/M NOSTURIAUTO	48
◆ 230 TN MOBIILINOSTURI	52
◆ 150 TN MOBIILINOSTURI	56
◆ 95 TN MOBIILINOSTURI	60
◇ TUOTEKUVIA	64
◆ PRIMUS, 8 T/M MININOSTURI	66
◆ JEKKO JF990	68
◆ JEKKO JF545	70
◇ TUOTEKUVIA	72
◇ LISÄVARUSTEET	76
◇ HISTORIA	80
◆ YMPÄRISTÖVASTUULLISUUS	83

Kalustoluettelossa mainitut mitat, painot ja nostoarvot ovat suuntaa-antavia.

215 T/M PERÄASENTEINEN PITKÄPUOMINOSTURIAUTO

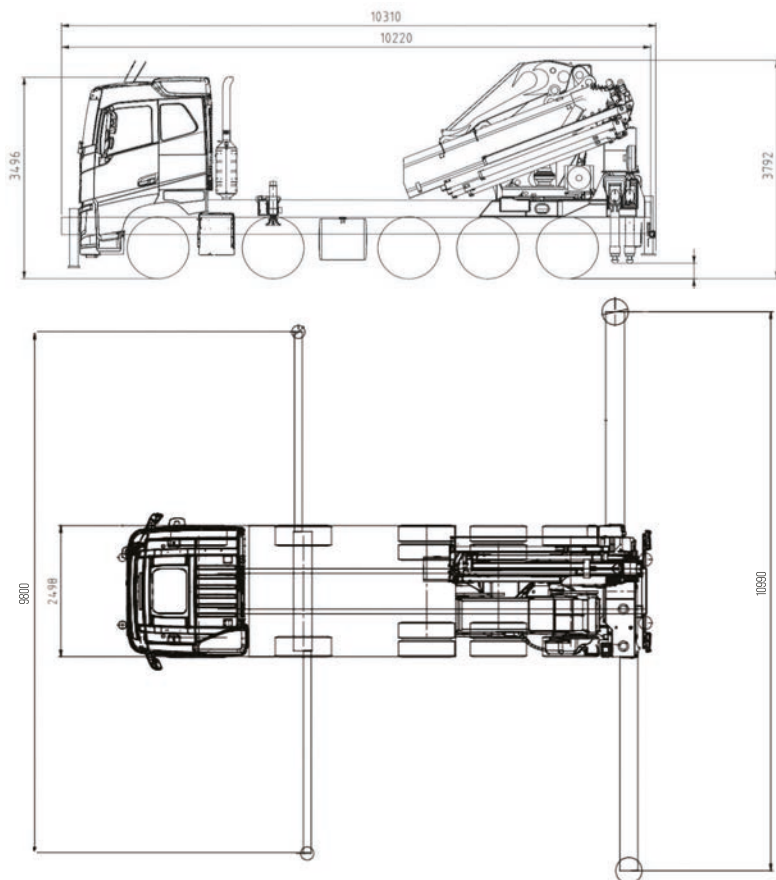
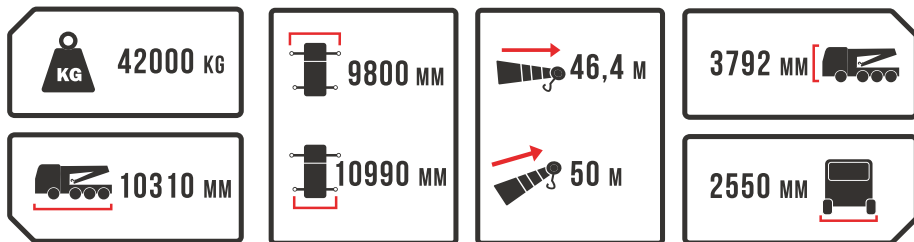

215 T/M PITKÄPUOMINOSTURIAUTO

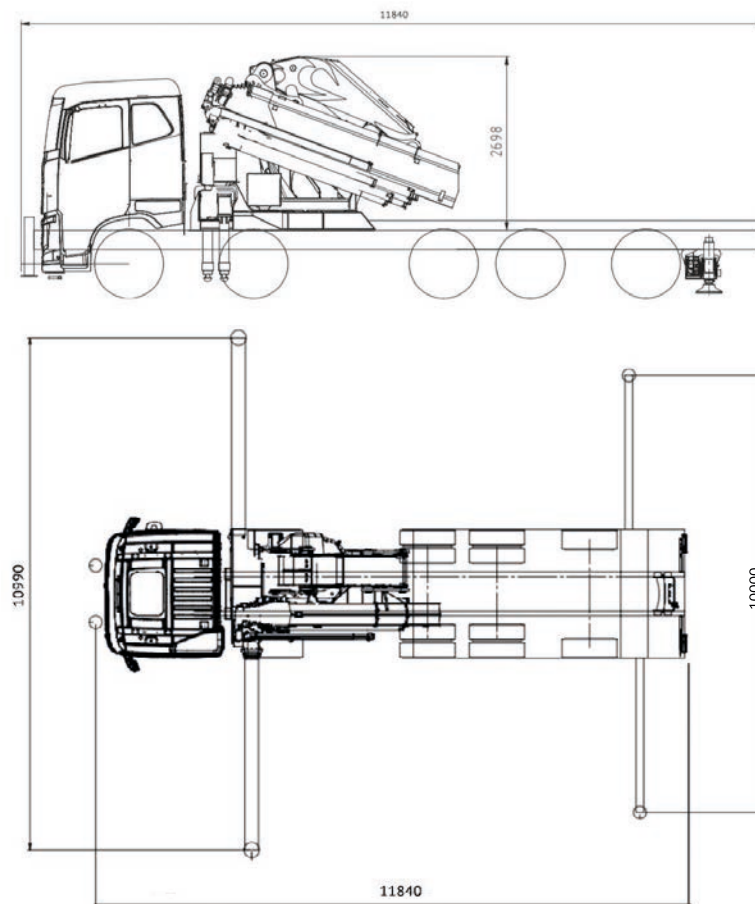
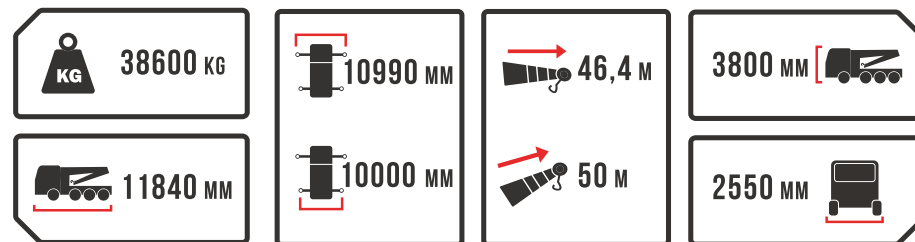

215 T/M PITKÄPUOMINOSTURIAUTO

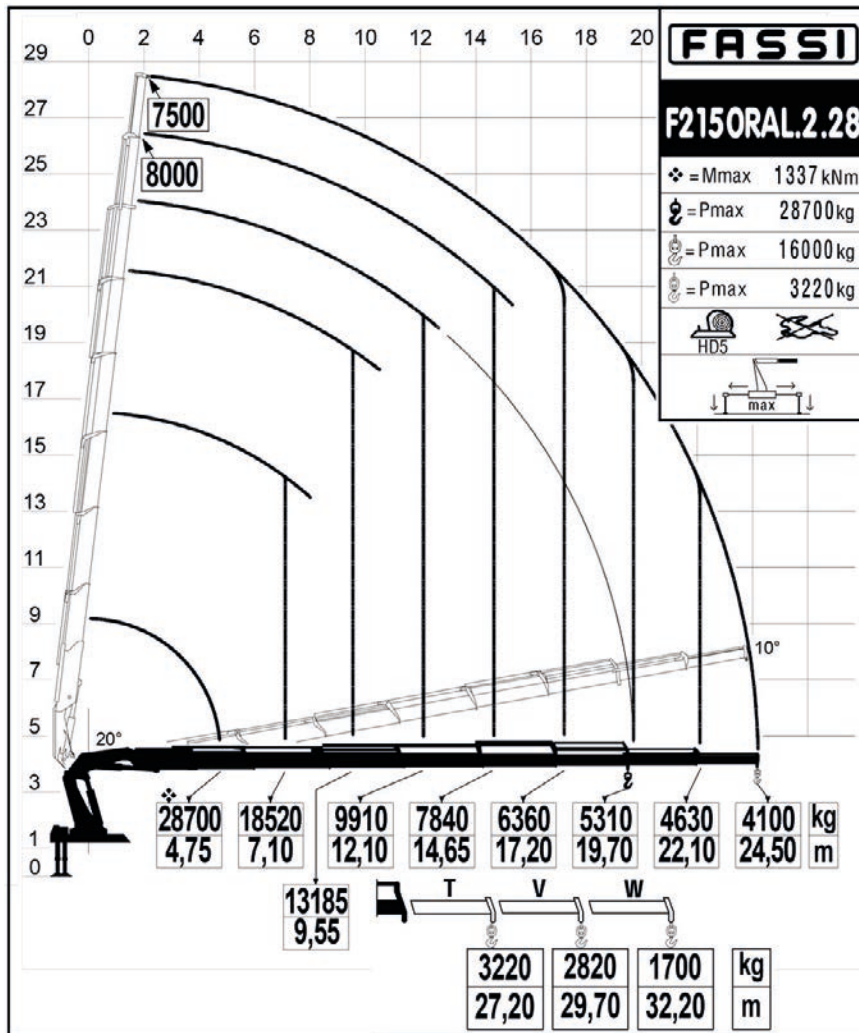

215 T/M PITKÄPUOMINOSTURIAUTO

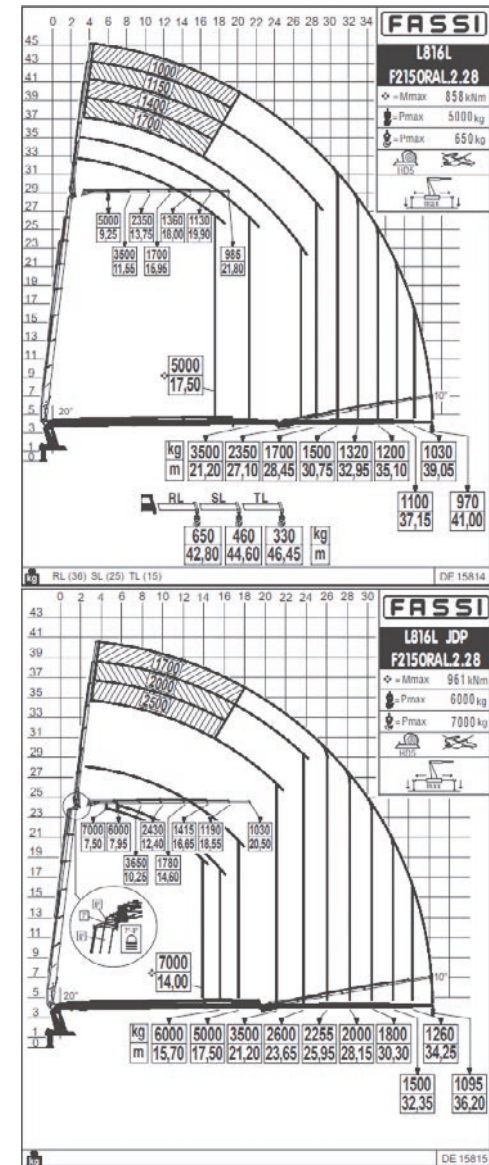



165 T/M PITKÄPUOMINOSTURIAUTO

39000 KG	9960 MM	46 M	3850 MM
11830 MM	8500 MM	50 M	2550 MM

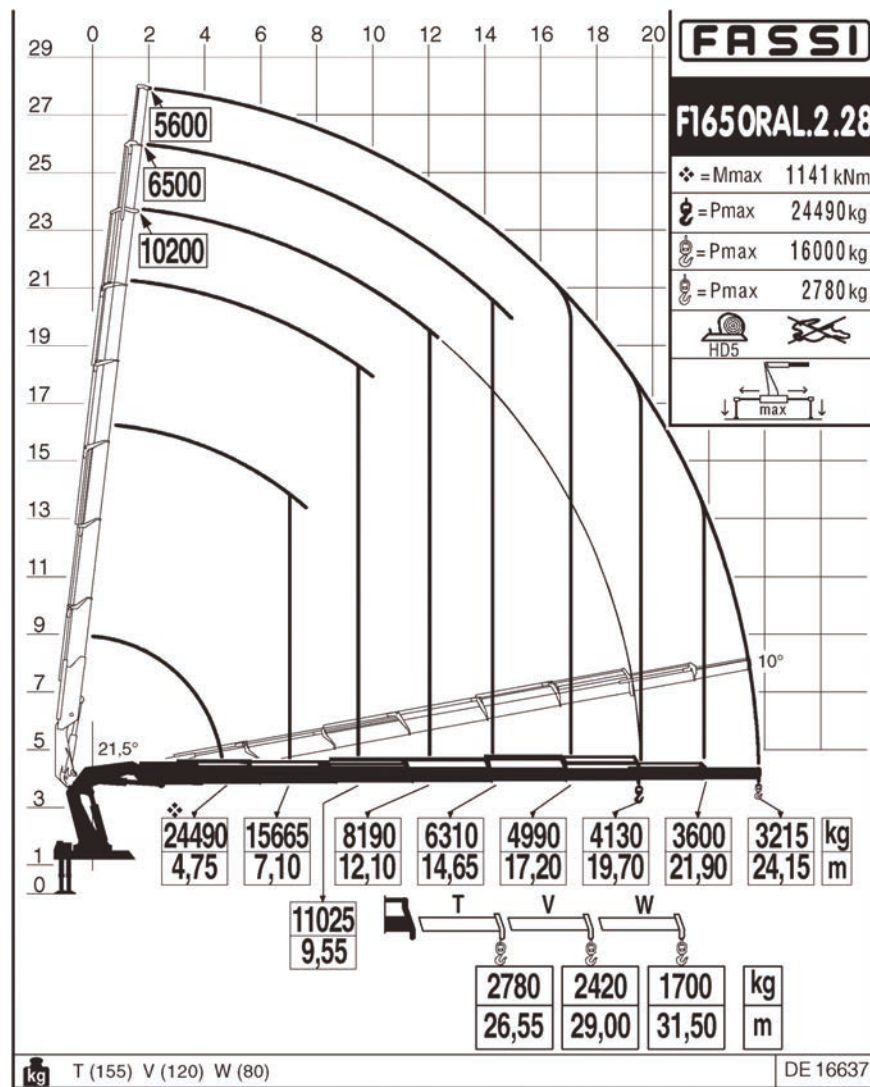
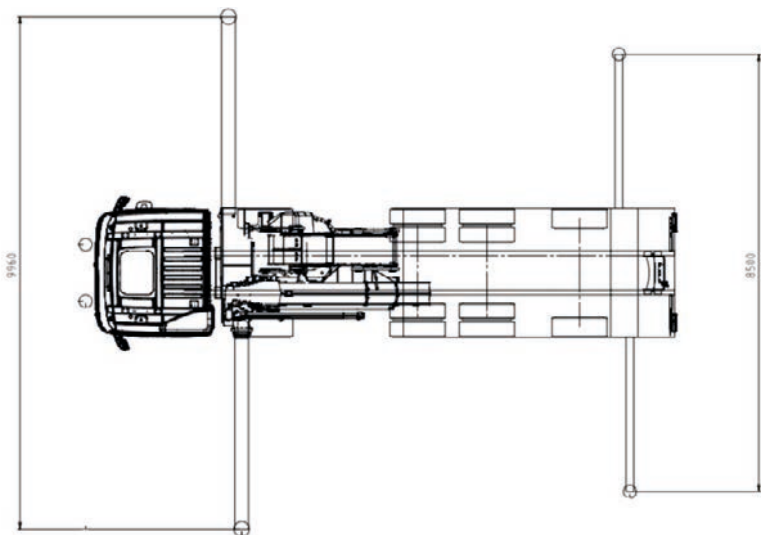
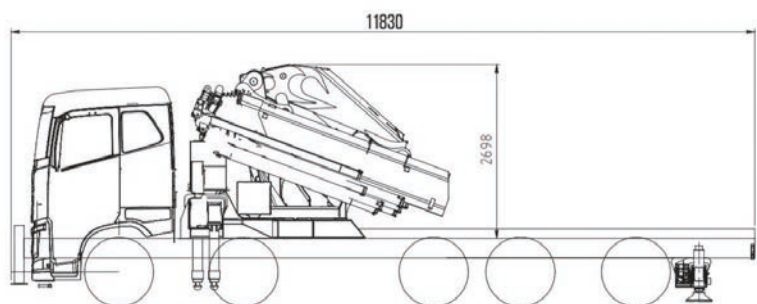

165 T/M NOSTURIAUTO

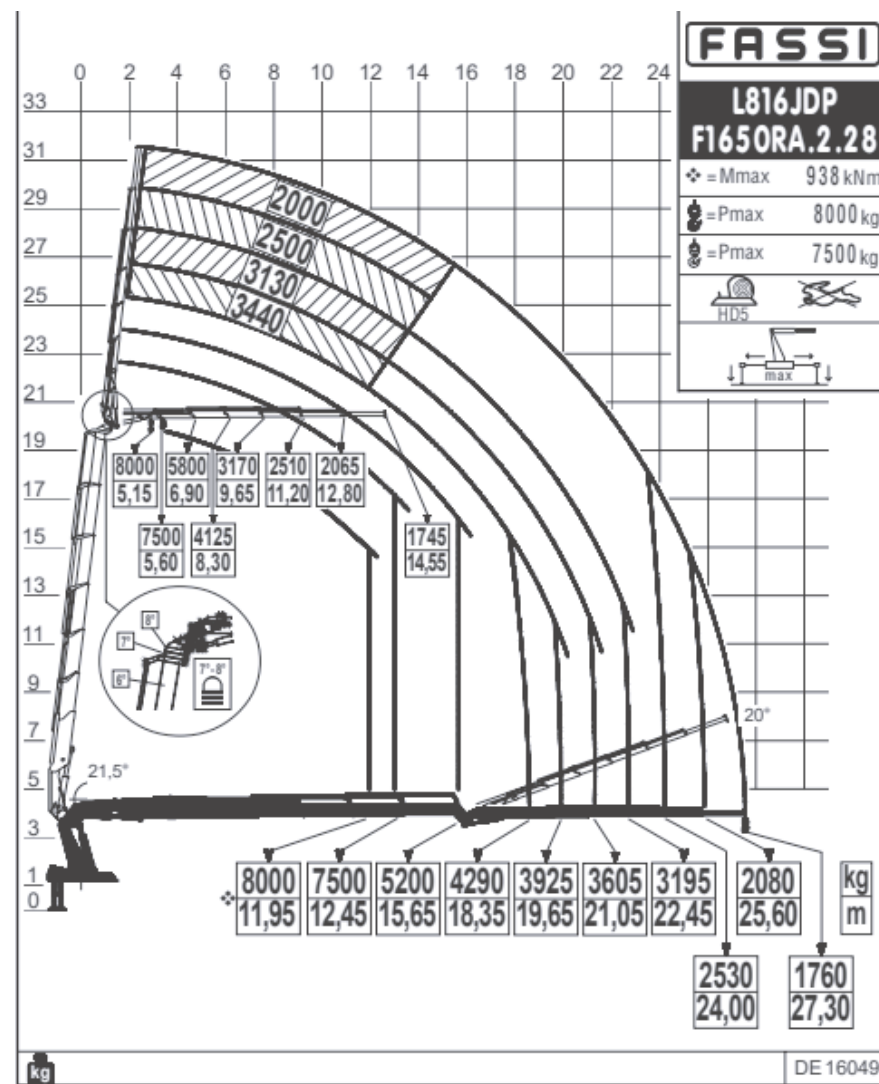
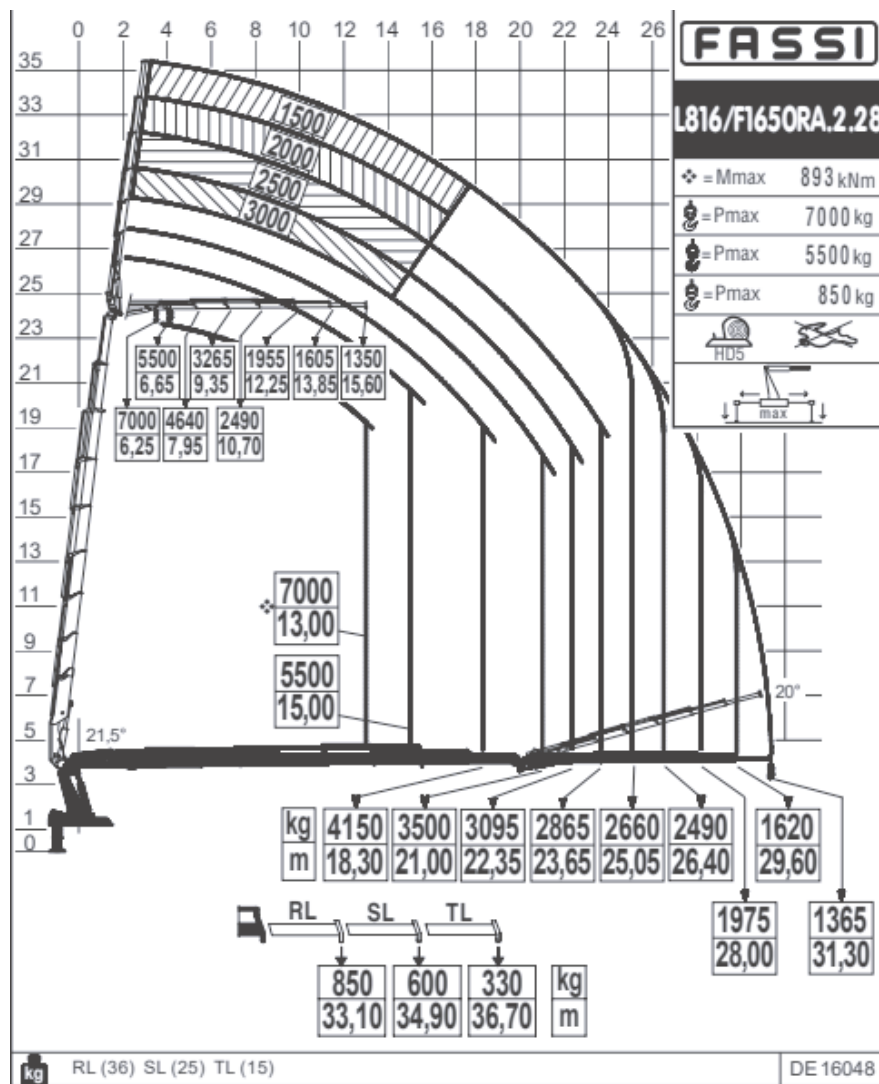

165 T/M NOSTURIAUTO

36400 KG	10000 MM	36,7 M	4000 MM
11690 MM	8500 MM	40 M	2550 MM

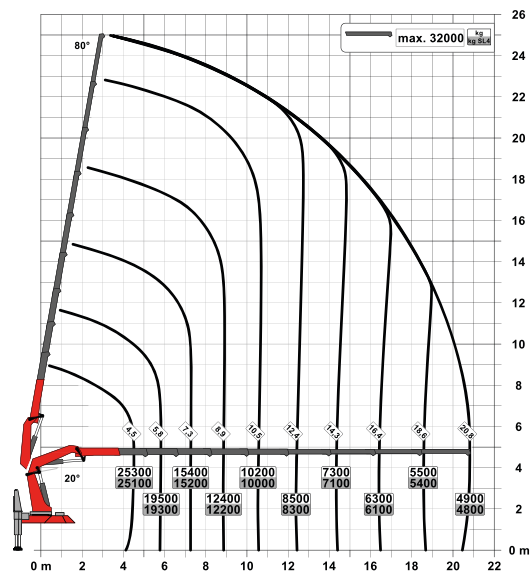
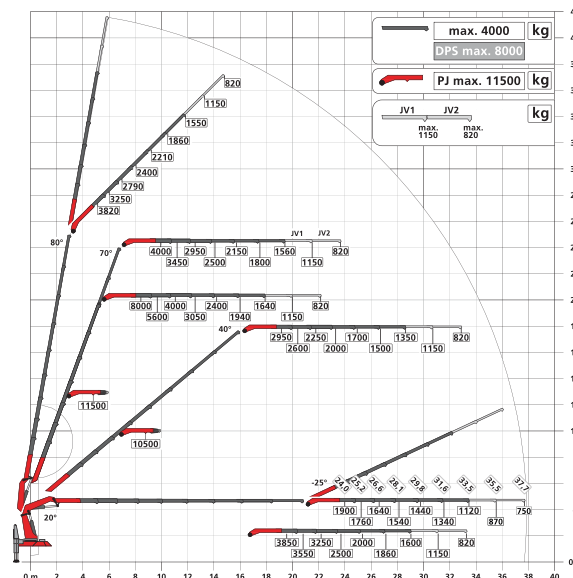
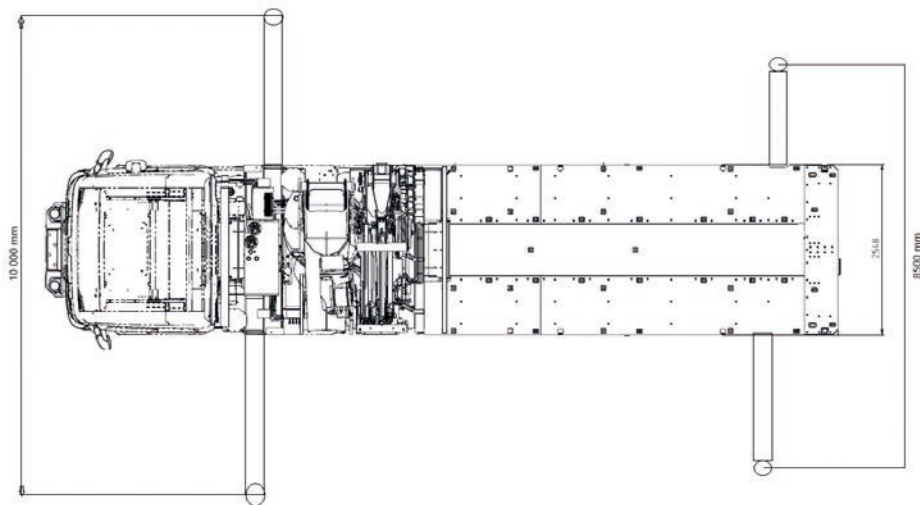
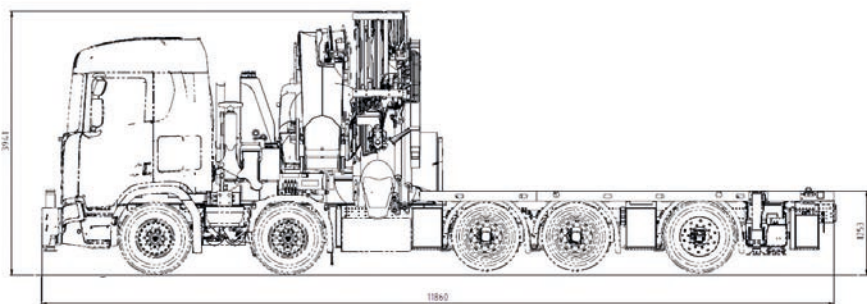



◆ 145 T/M NOSTURIAUTO

37000 KG	10000 MM	31,5 M	4000 MM
11906 MM	7500 MM	35 M	2550 MM

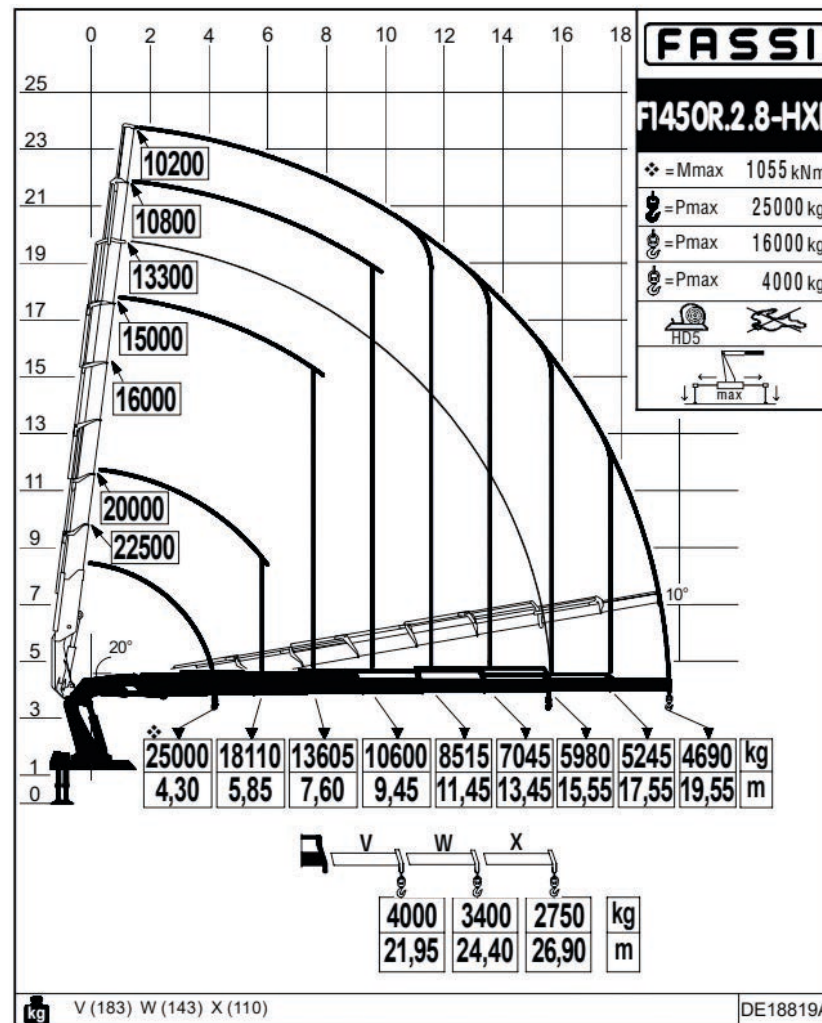
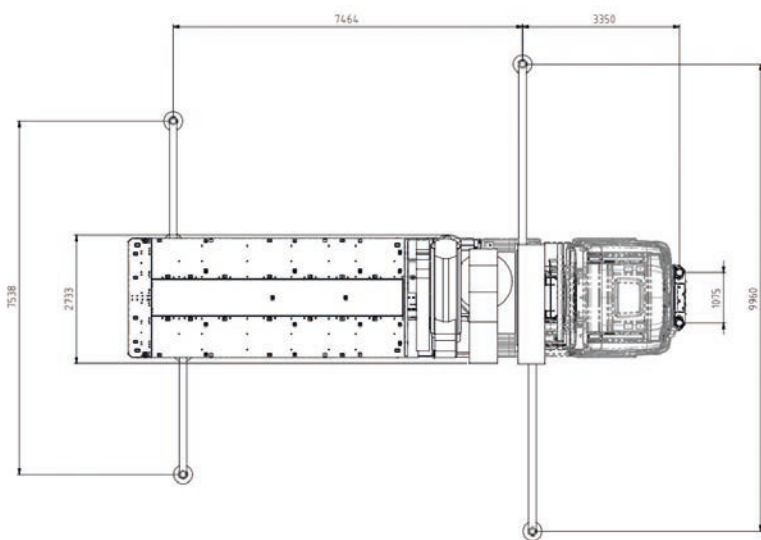
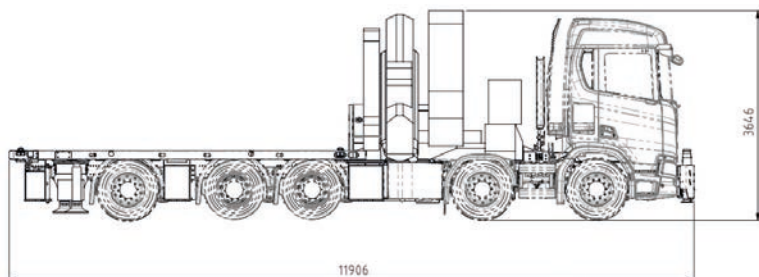

◆ 145 T/M NOSTURIAUTO

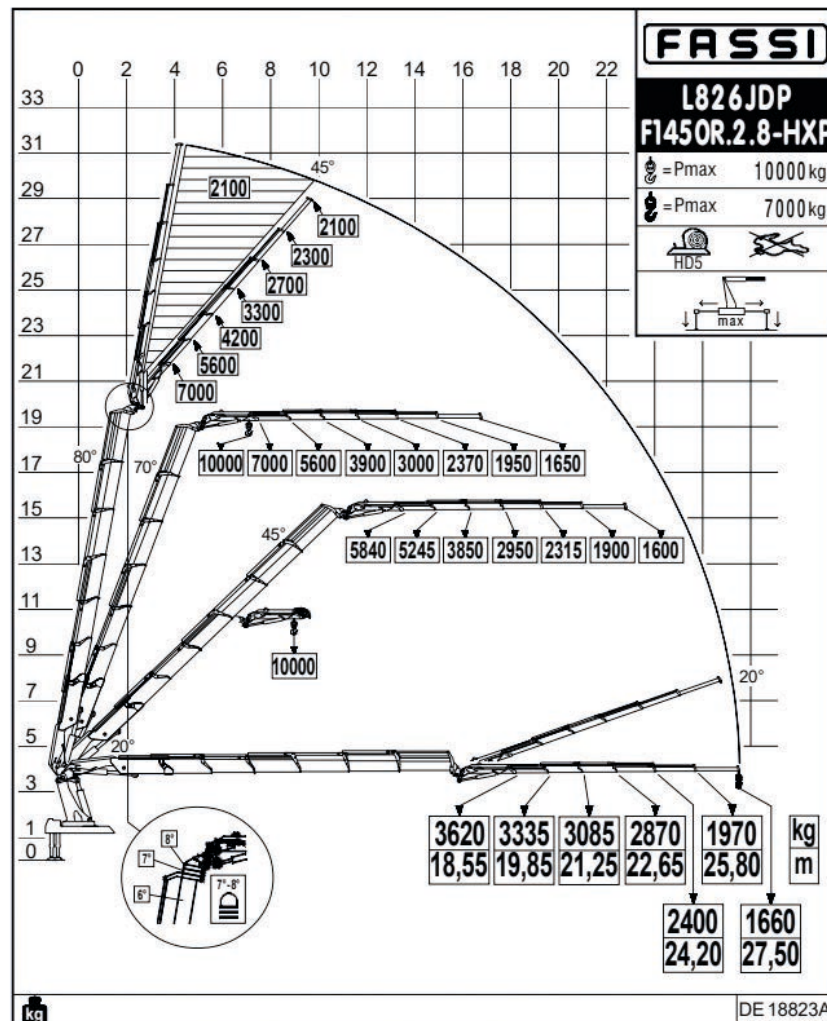
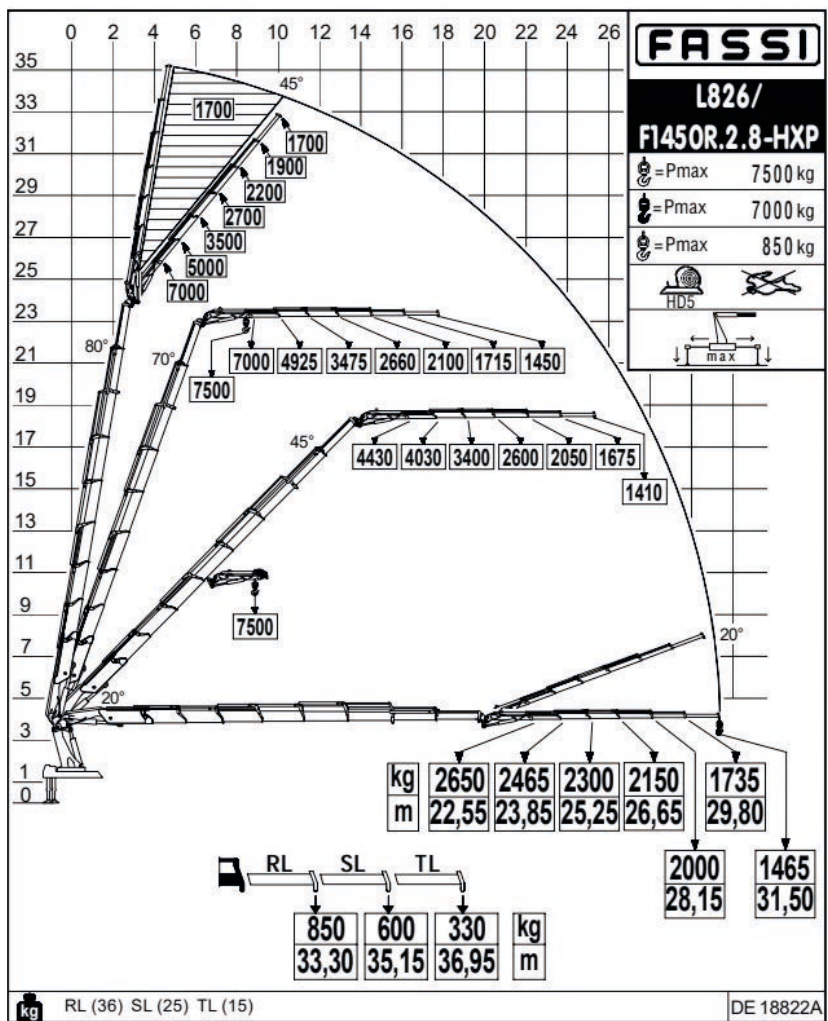

135 T/M NOSTURIAUTO

35000 KG	10000 MM	37 M	4000 MM
11860 MM	7100 MM	40 M	2550 MM

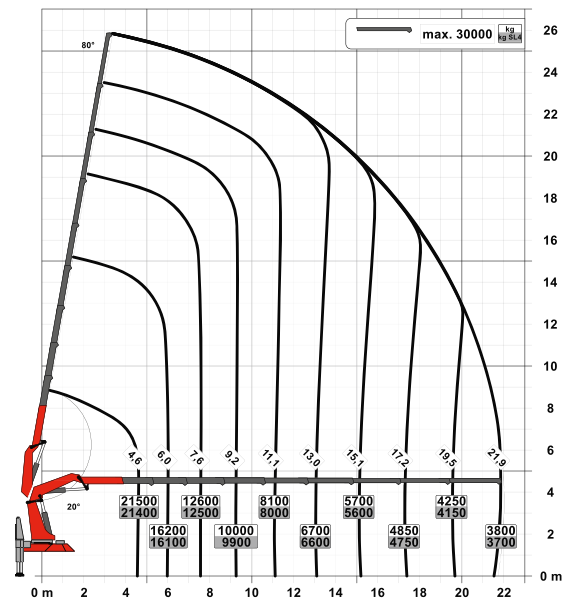
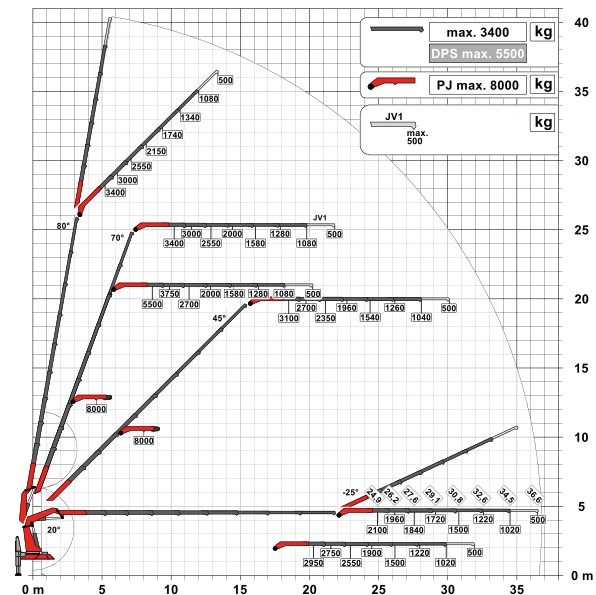
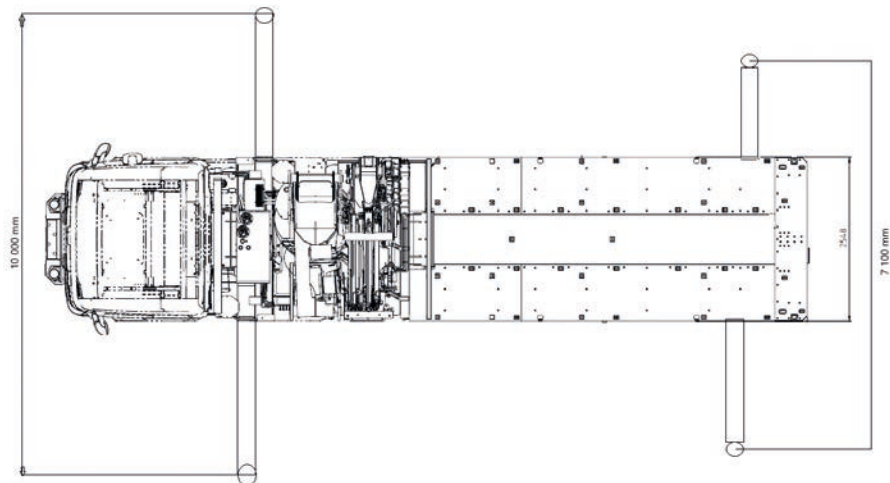
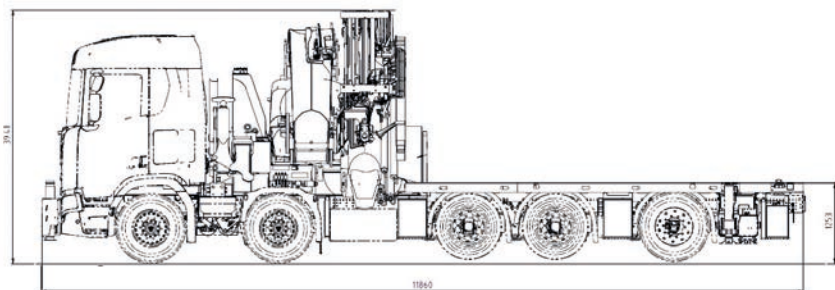

115 T/M NOSTURIAUTO

28000 KG	8840 MM	36,9 M	3755 MM
10913 MM	6670 MM	40 M	2550 MM

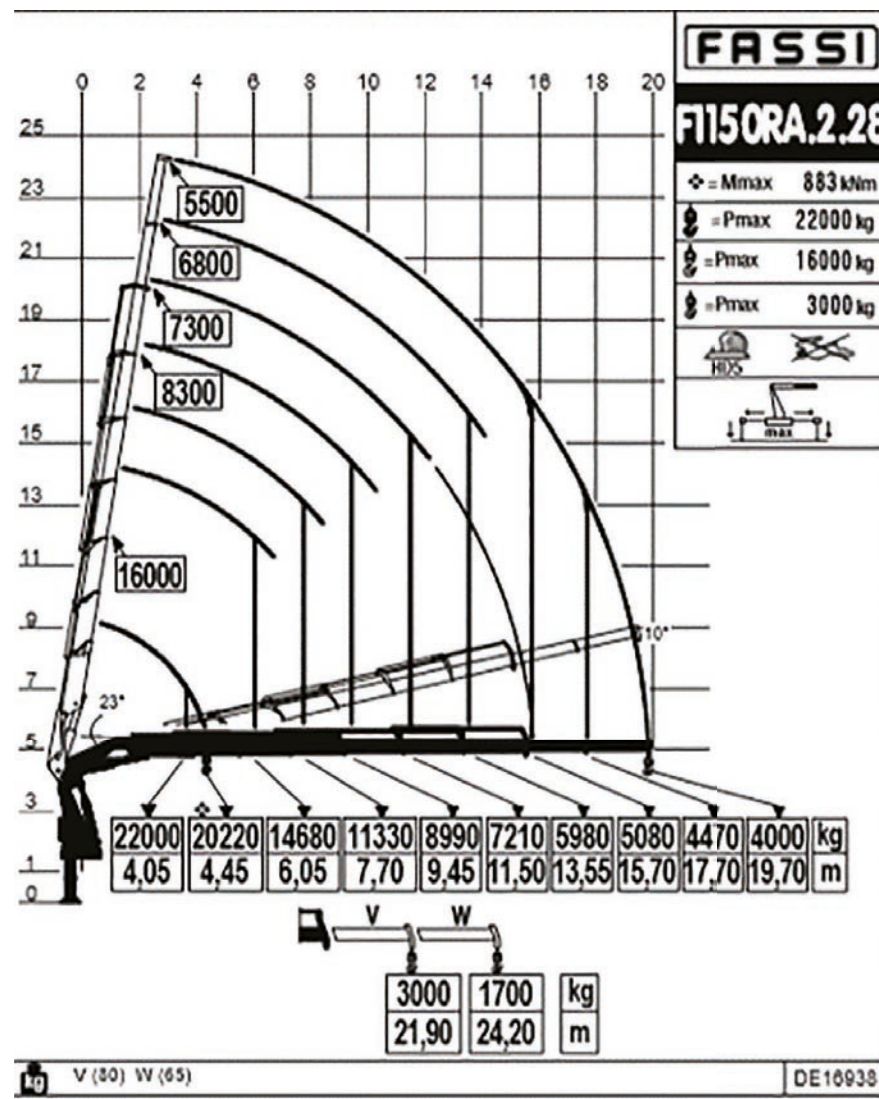
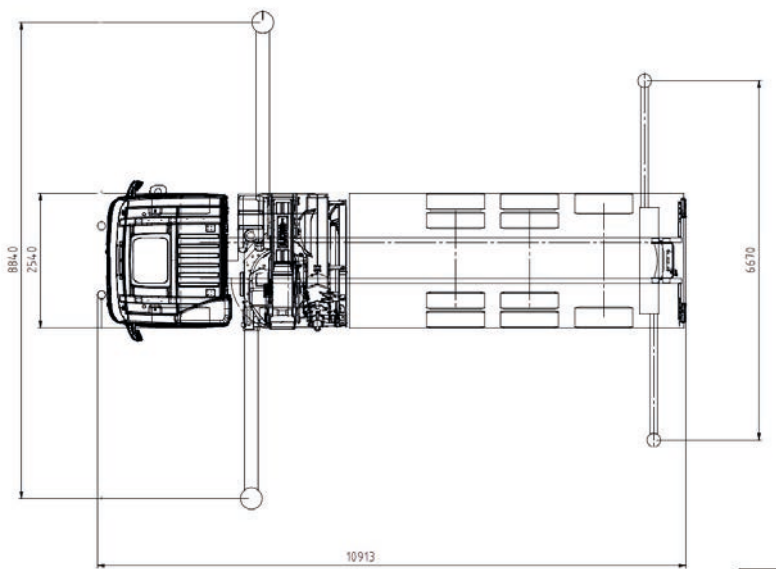
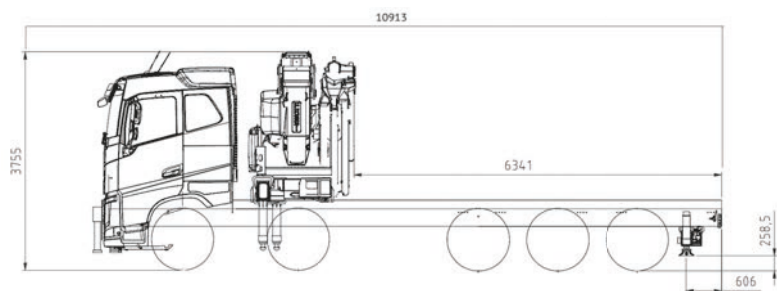

◆ 115 T/M NOSTURIAUTO

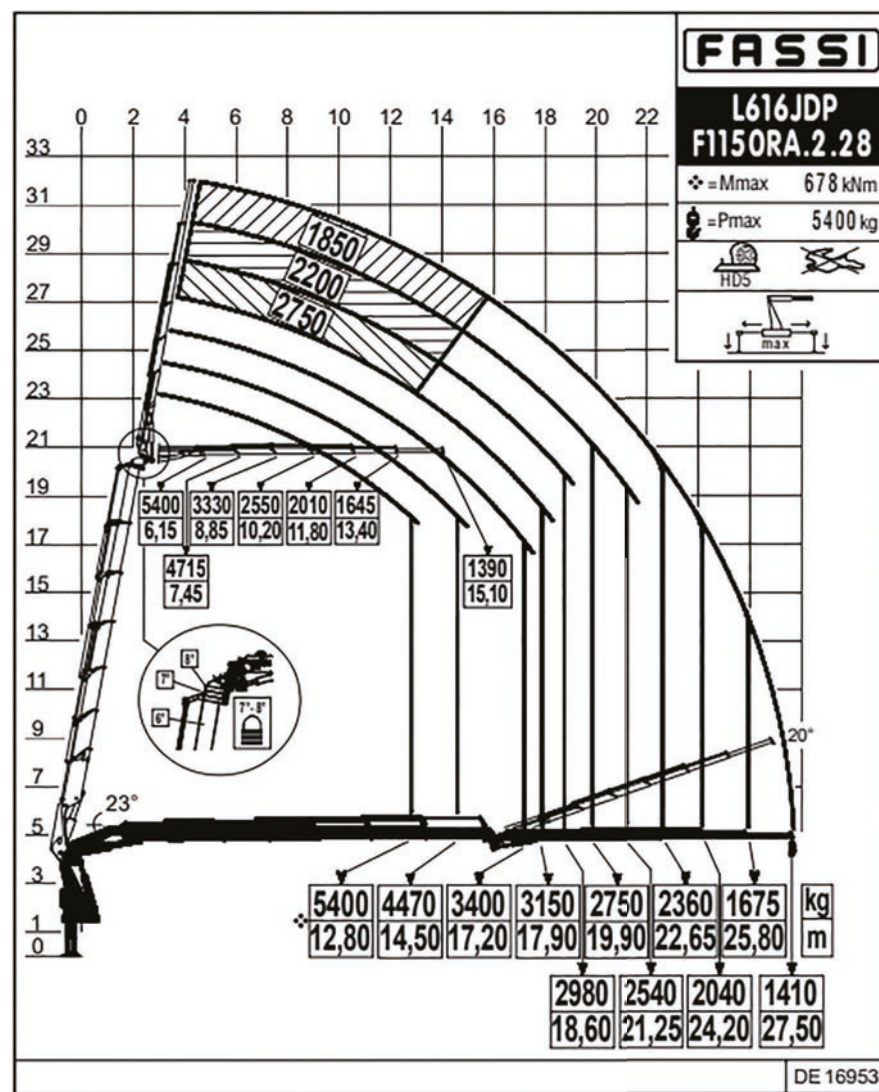
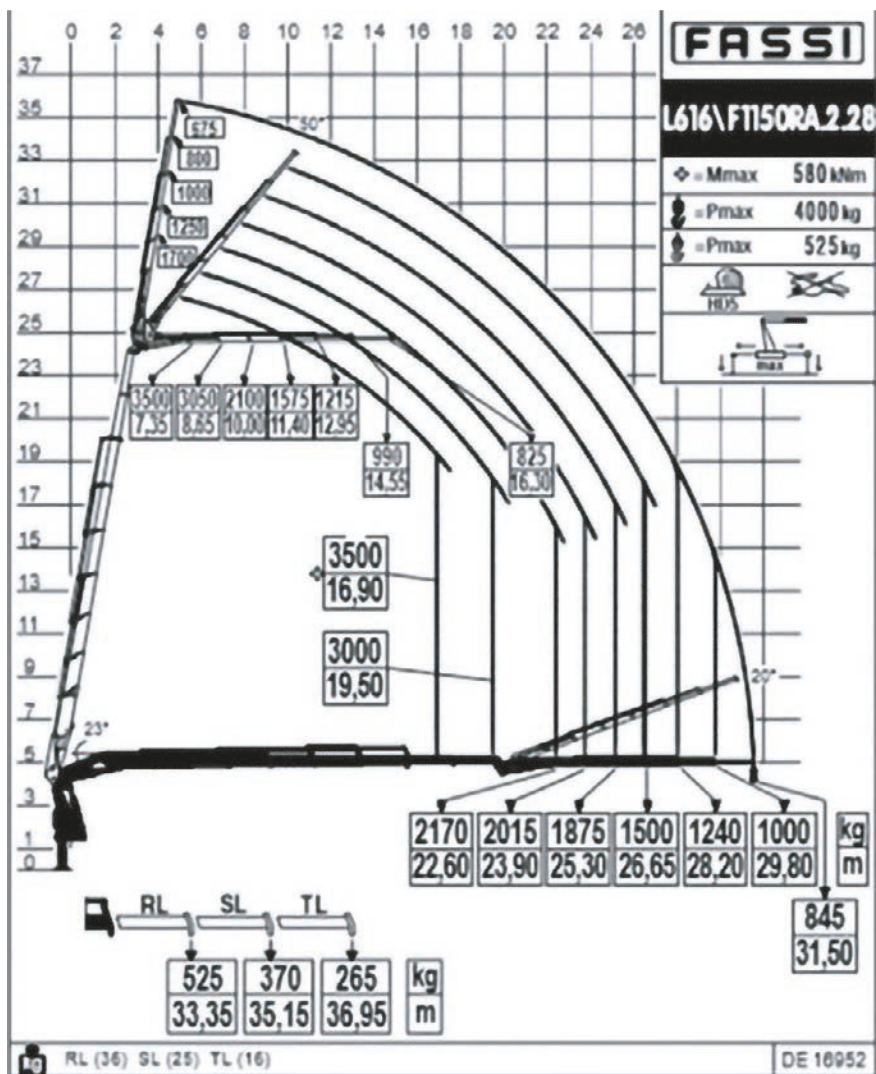

◆ 100 T/M NOSTURIAUTO

33000 KG	9100 MM	33,5 M	4000 MM
11858 MM	5950 MM	37,5 M	2550 MM

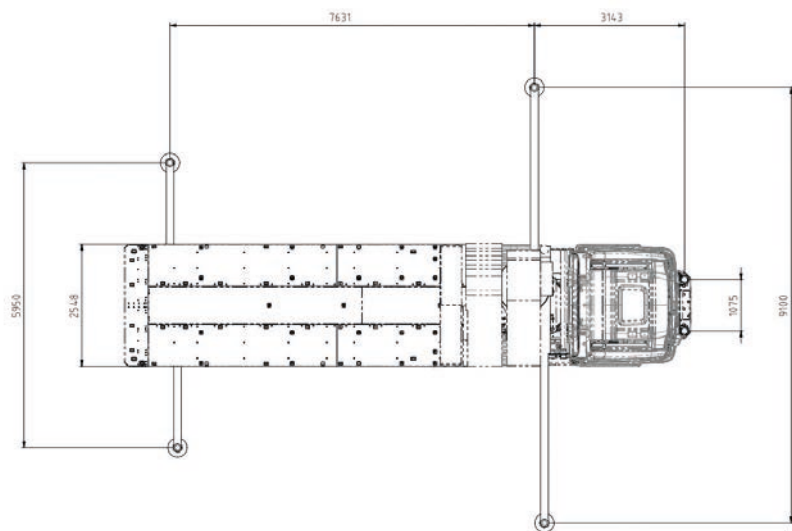
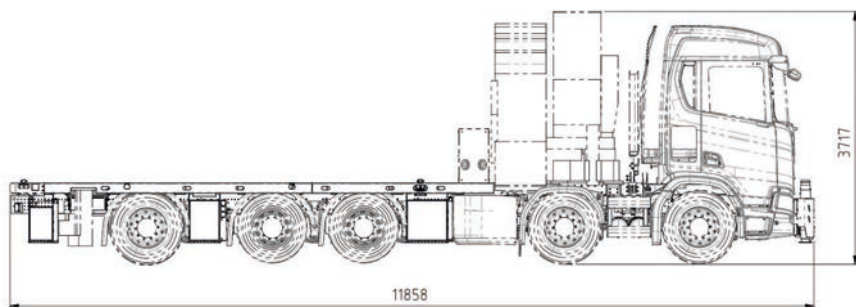

100028 SP

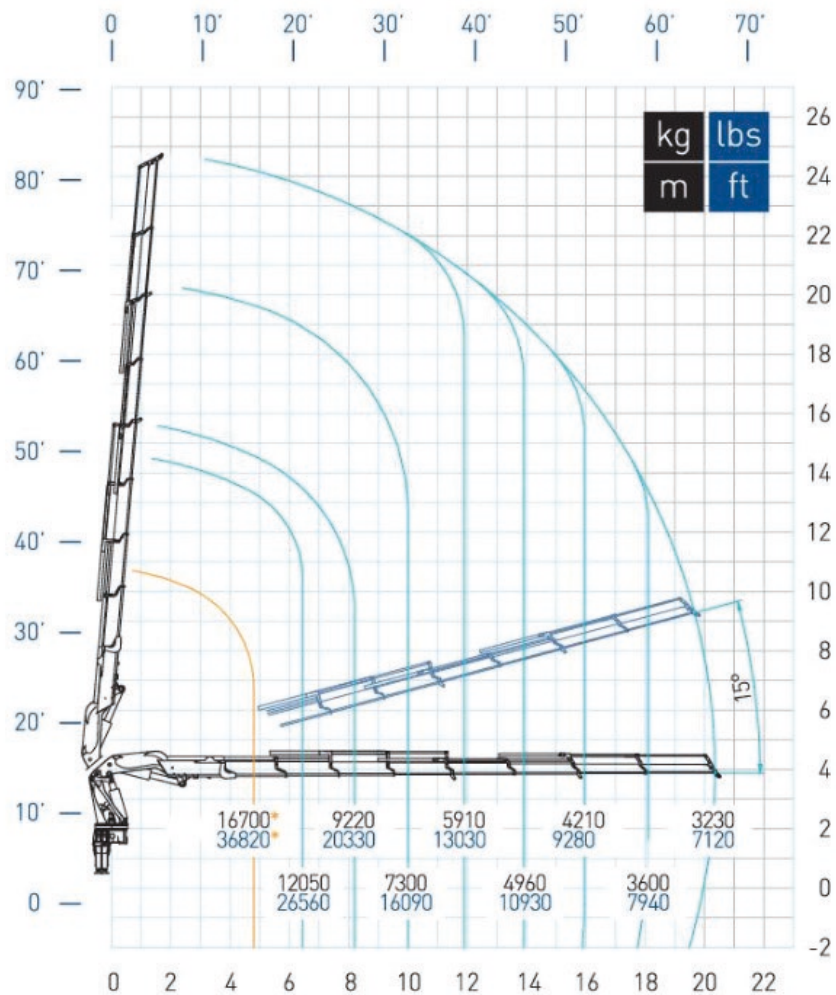

◆ 100 T/M NOSTURIAUTO

100028 SP + J1616.25

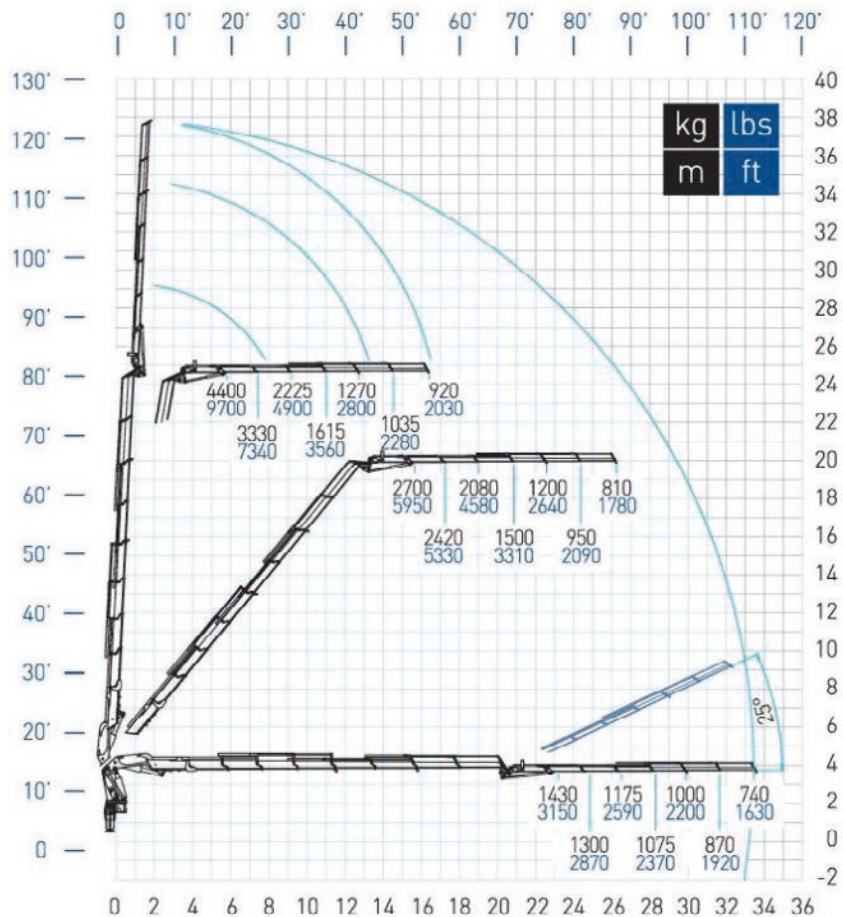

105 T/M NOSTURIAUTO

32500 KG	10000MM	33,3 M	3679 MM
11859 MM	5900 MM	34 M	2548 MM

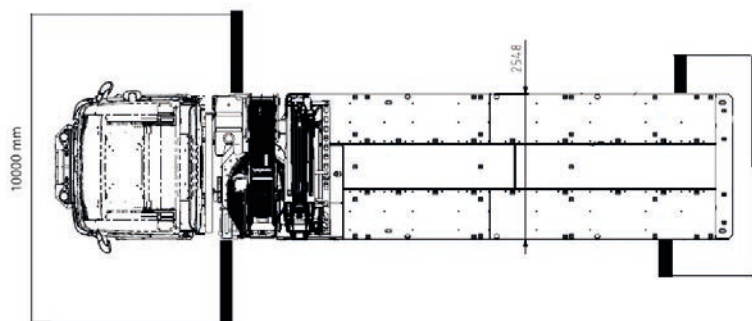
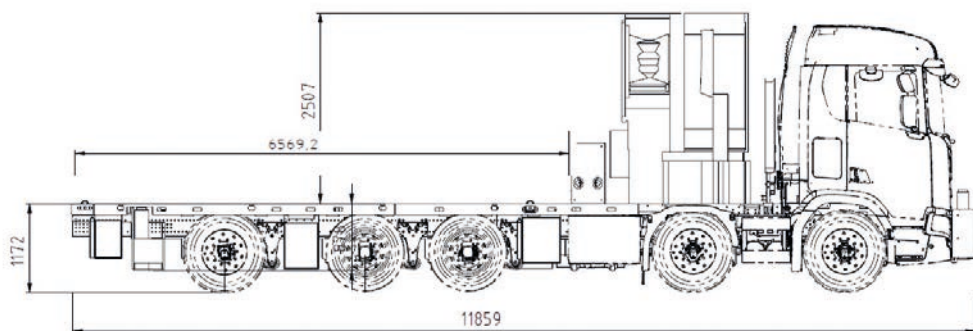

HIAB X-HIPRO 1058 EP-6

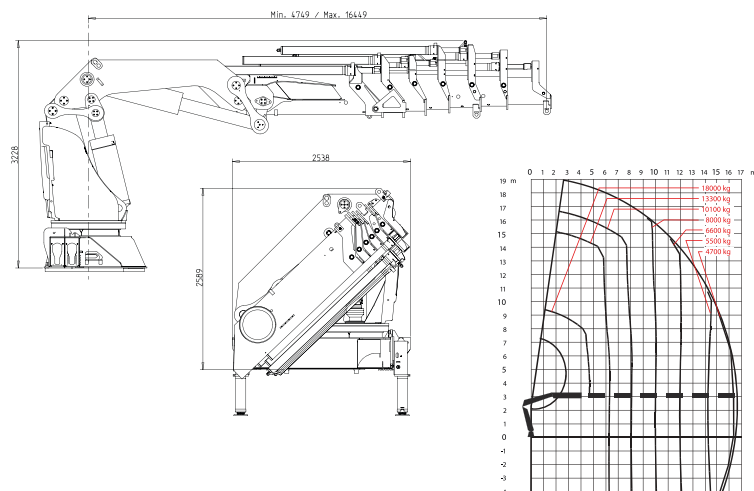

HIAB X-HIPRO 1058 E-8 + JIB 150X-6

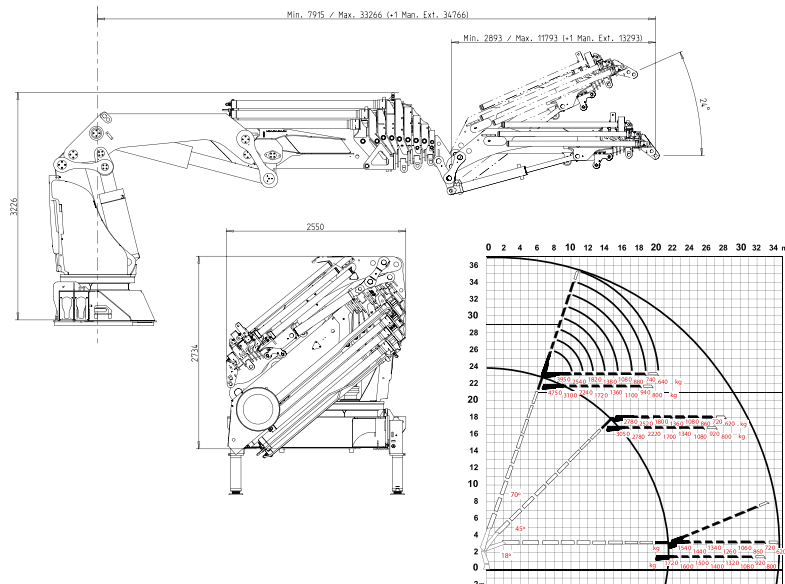

99 T/M NOSTURIAUTO

25300 KG	8500 MM	37 M	3800 MM
10550 MM	5800 MM	40 M	2550 MM

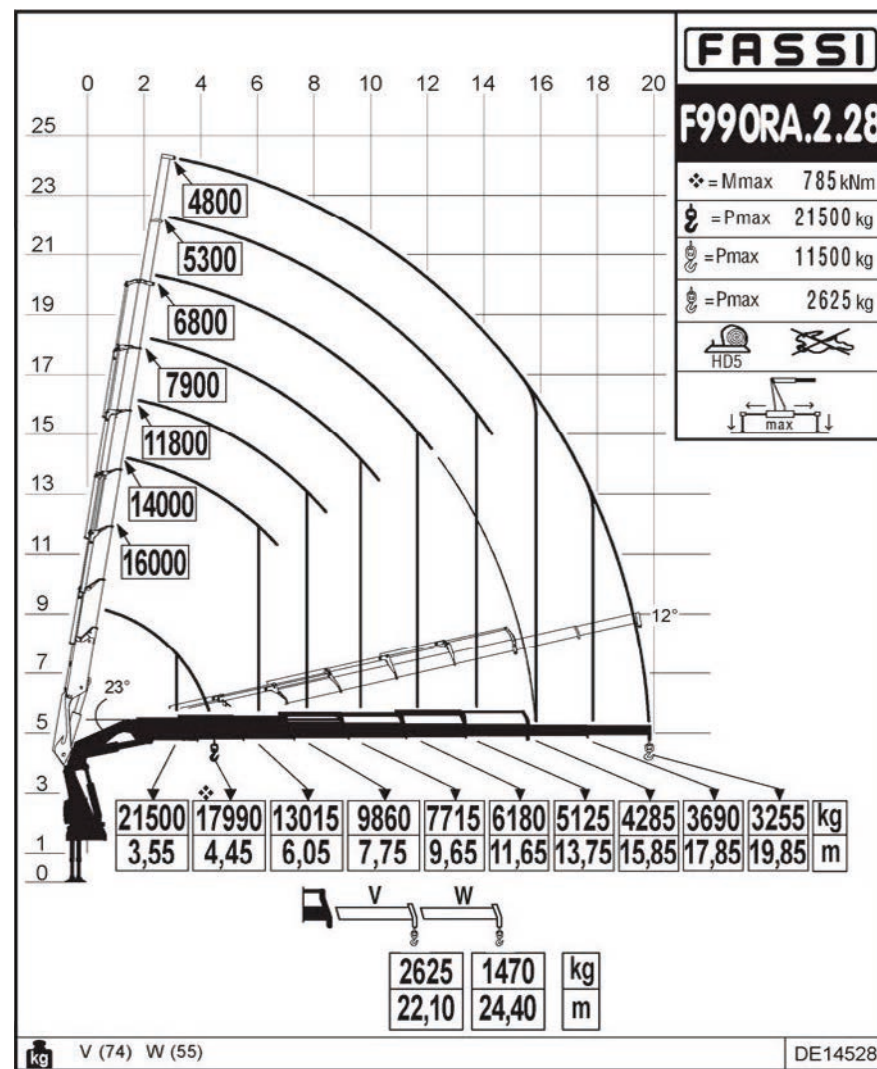
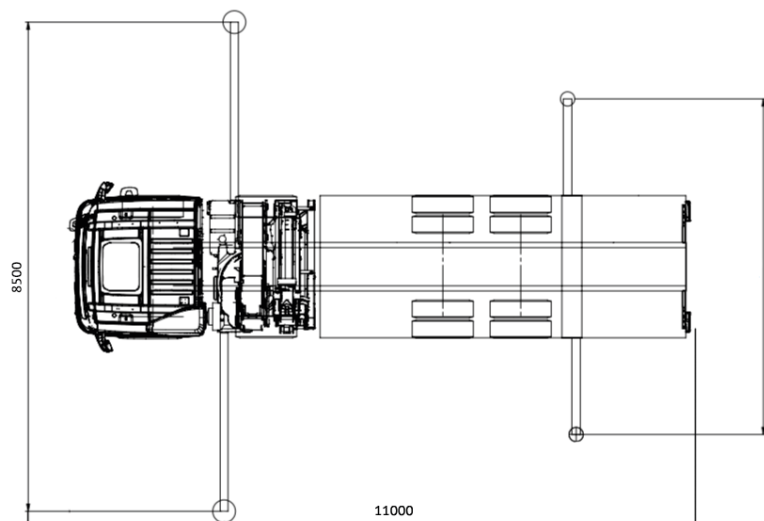
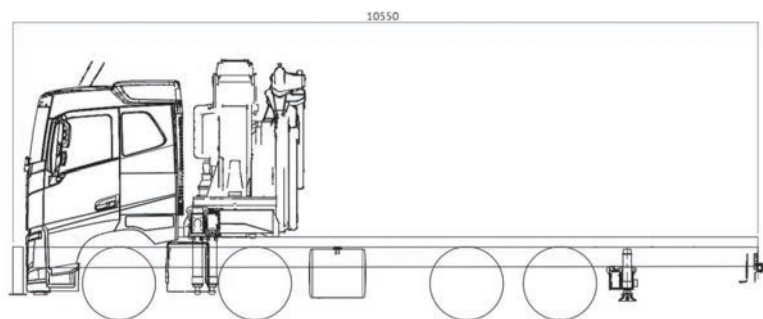

99 T/M NOSTURIAUTO

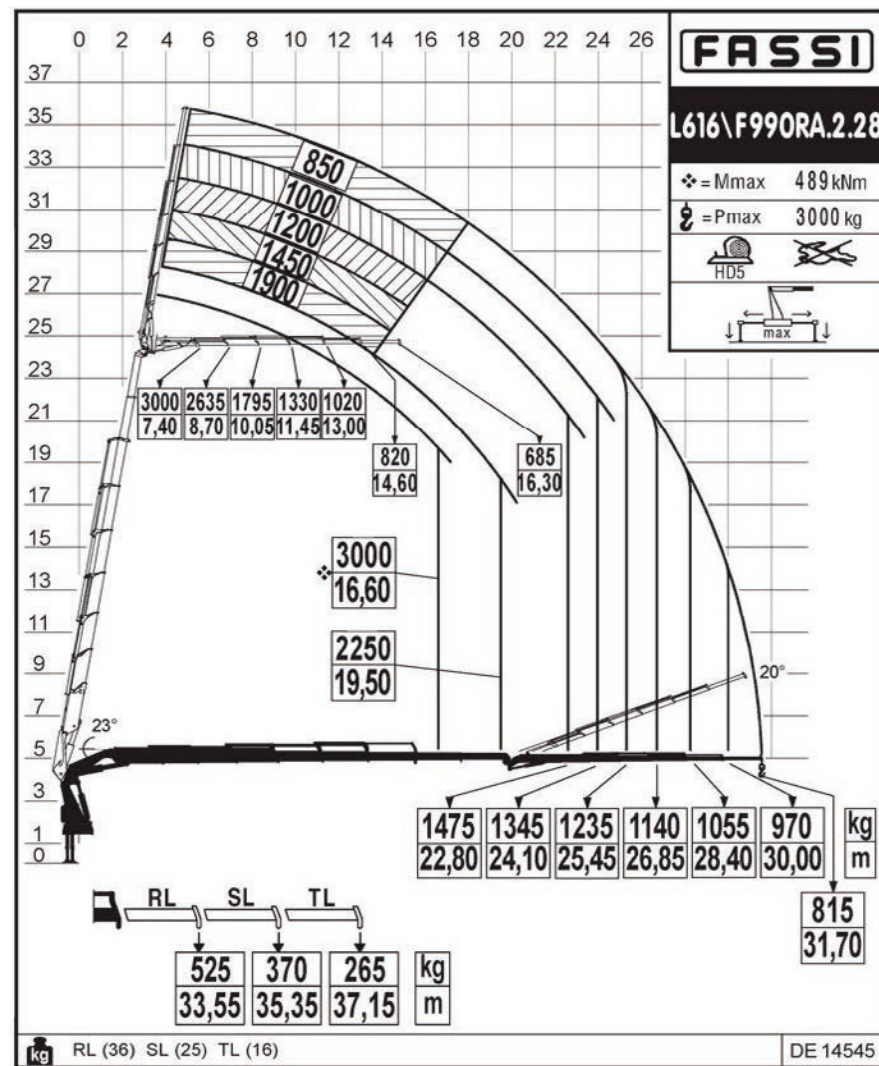
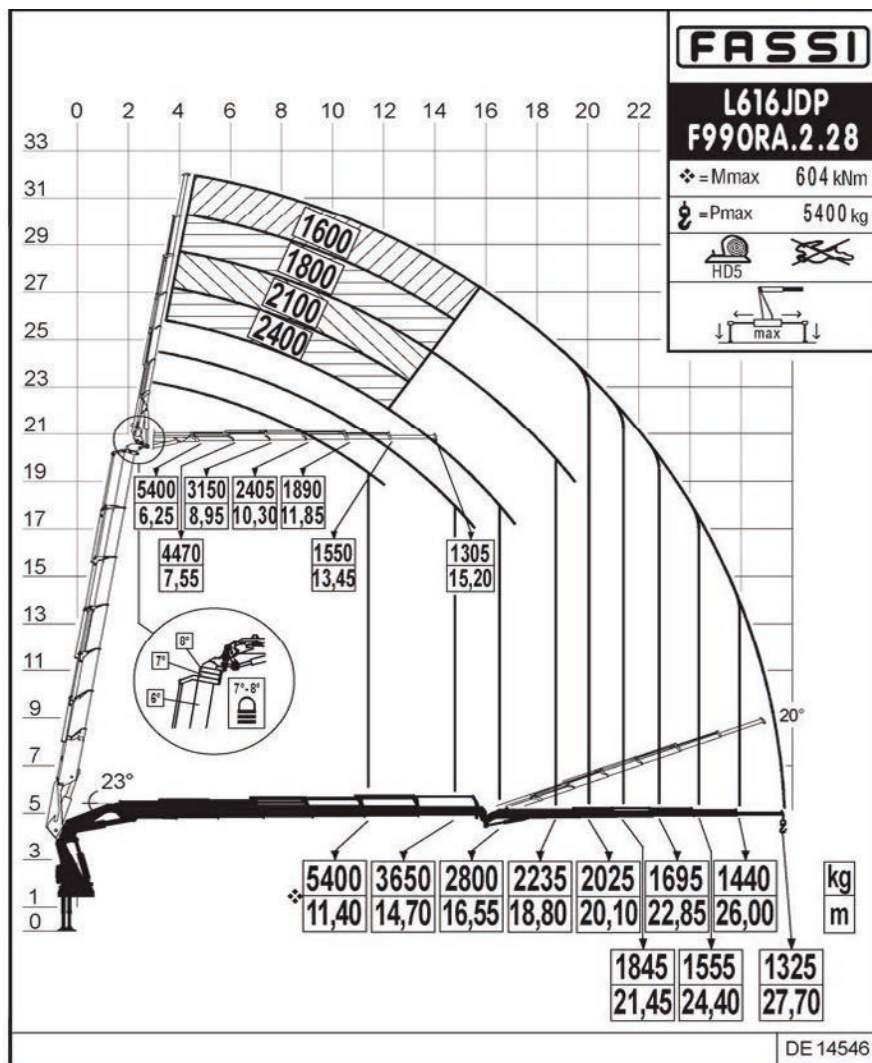



◆ 95 T/M NOSTURIAUTO

26850 KG	8500 MM	32 M	3800 MM
11000 MM	5800 MM	36 M	2550 MM

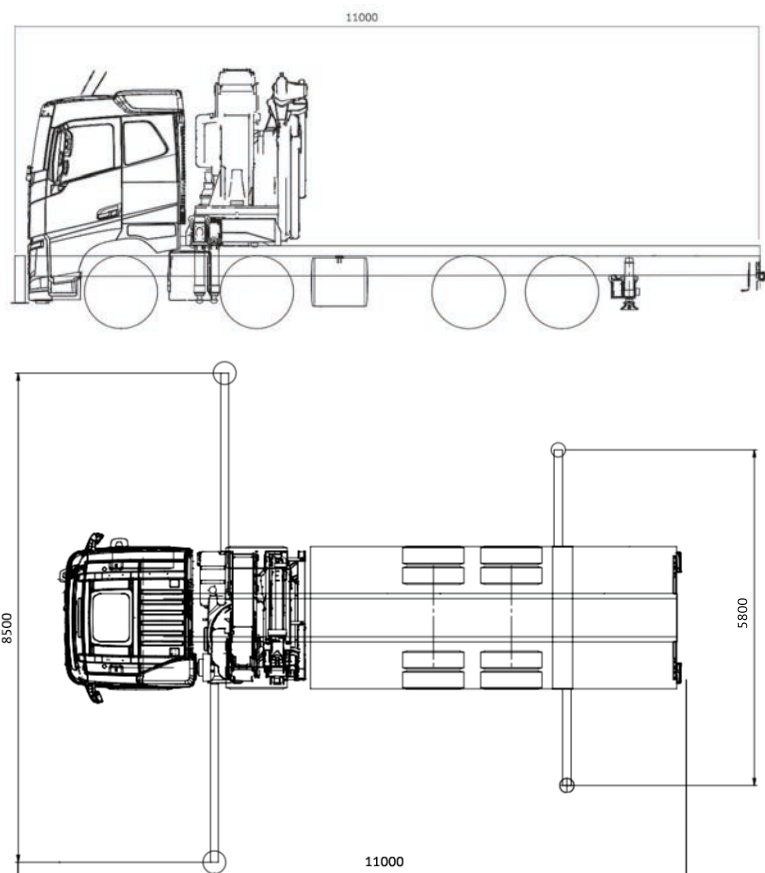

FASSI

Via Roma, 110
14021 Albino (BG)
Tel.: +39 035 776400
Fax: +39 035 755020
www.fassi.com
fassi@fassi.com

F950RA.2.26 he-dynamic - Load Diagram

LOAD DIAGRAM WITH LIFTING MOMENT LIMITING DEVICE

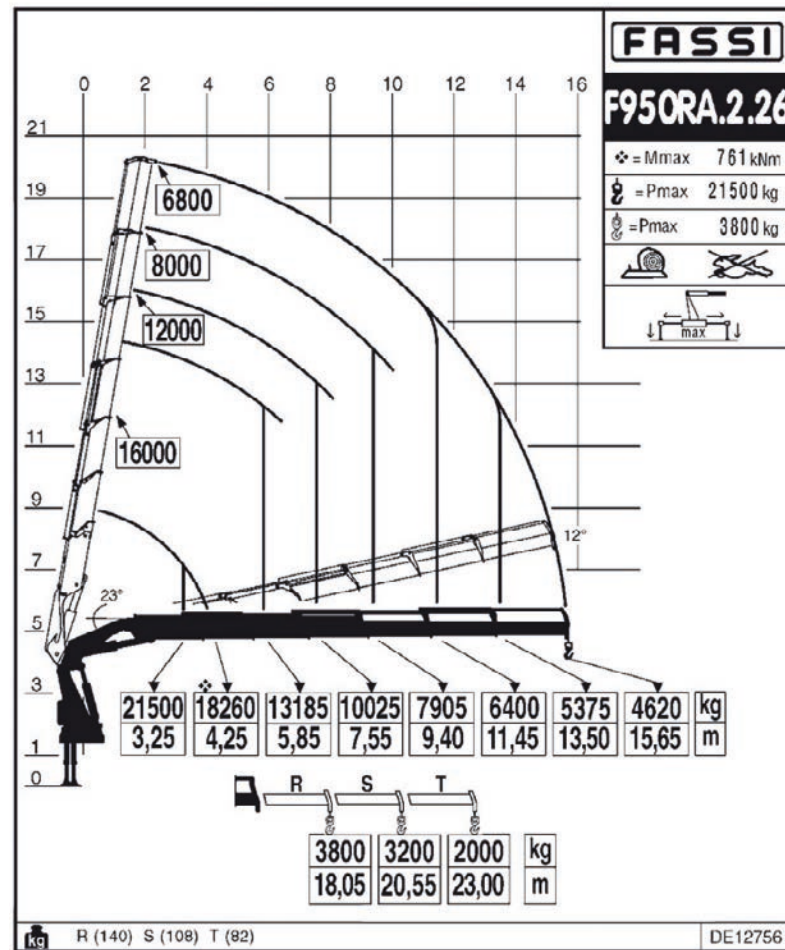

◆ 95 T/M NOSTURIAUTO

FASSI

F950RA.2.26/L616 he-dynamic - Load Diagram

Via Roma, 110
14021 Albino (BG)
Tel.: +39 035 770400
Fax: +39 035 755020
www.fassi.com
fassi@fassi.com

LOAD DIAGRAM HYDRAULIC EXTENSIONS WITH LIFTING MOMENT LIMITING DEVICE

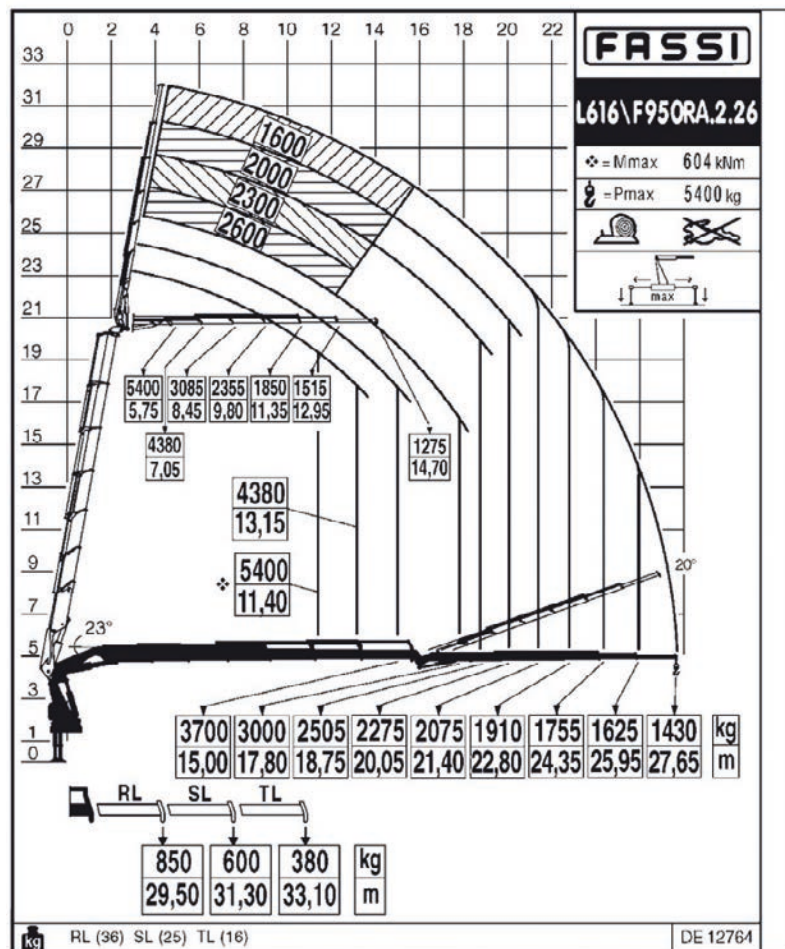

◆ 92 T/M NOSTURIAUTO

27400 KG	8600 MM	32 M	3770 MM
10950 MM	5900 MM	36 M	2550 MM

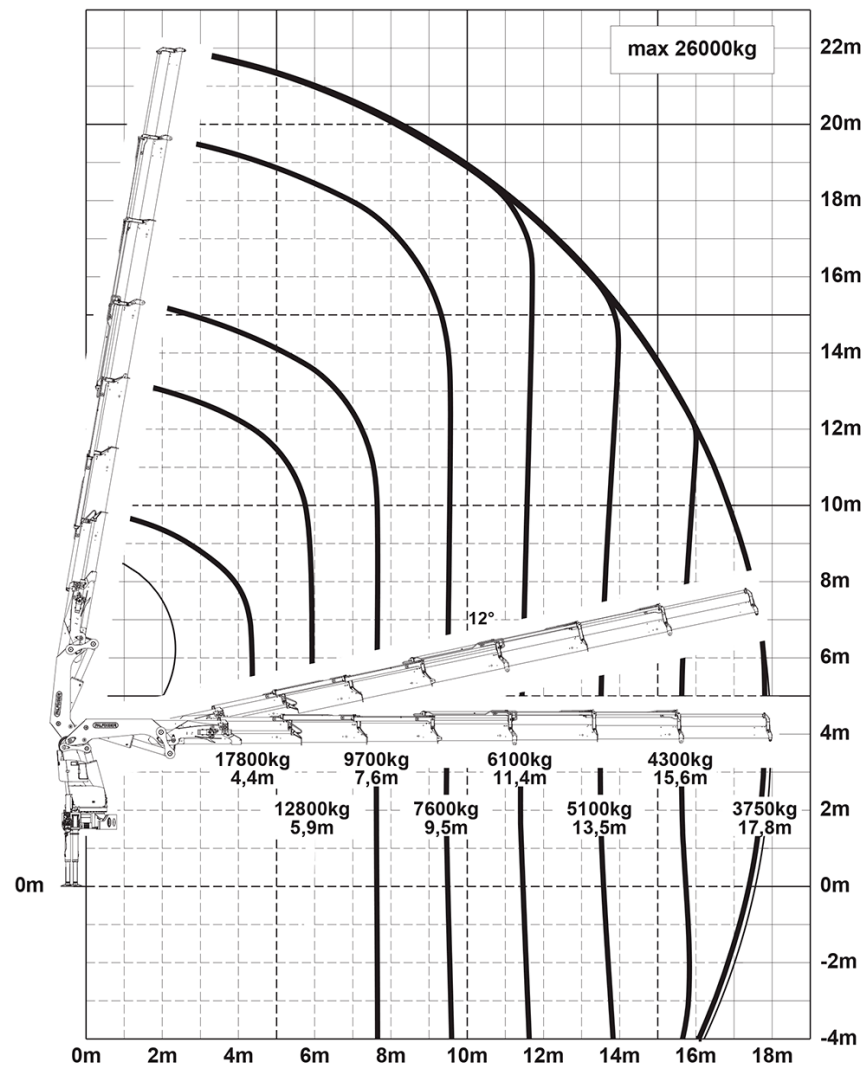
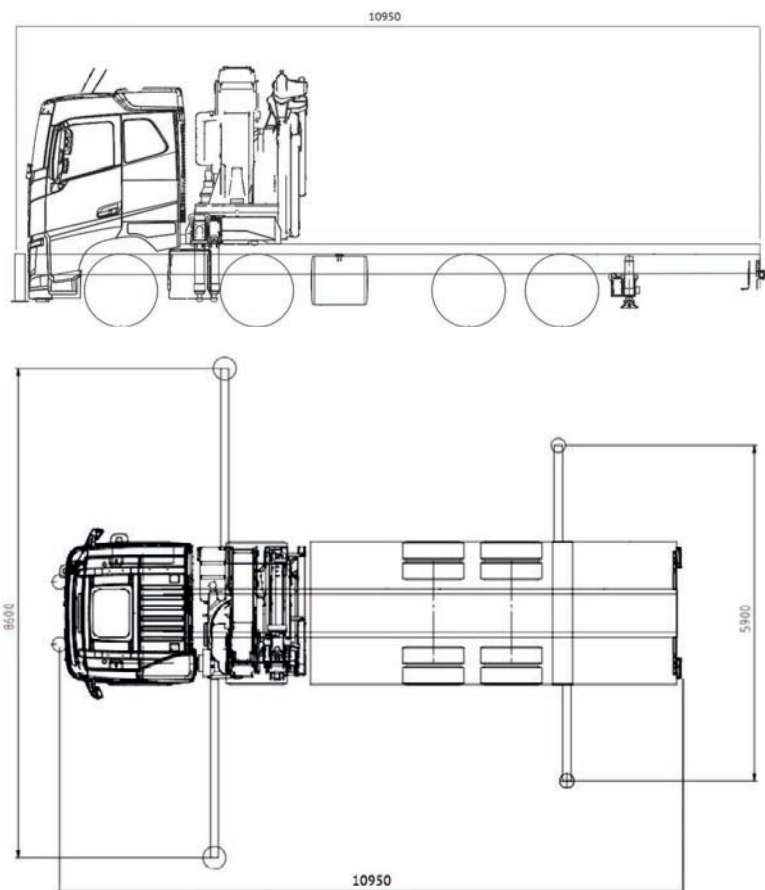

92 T/M NOSTURIAUTO

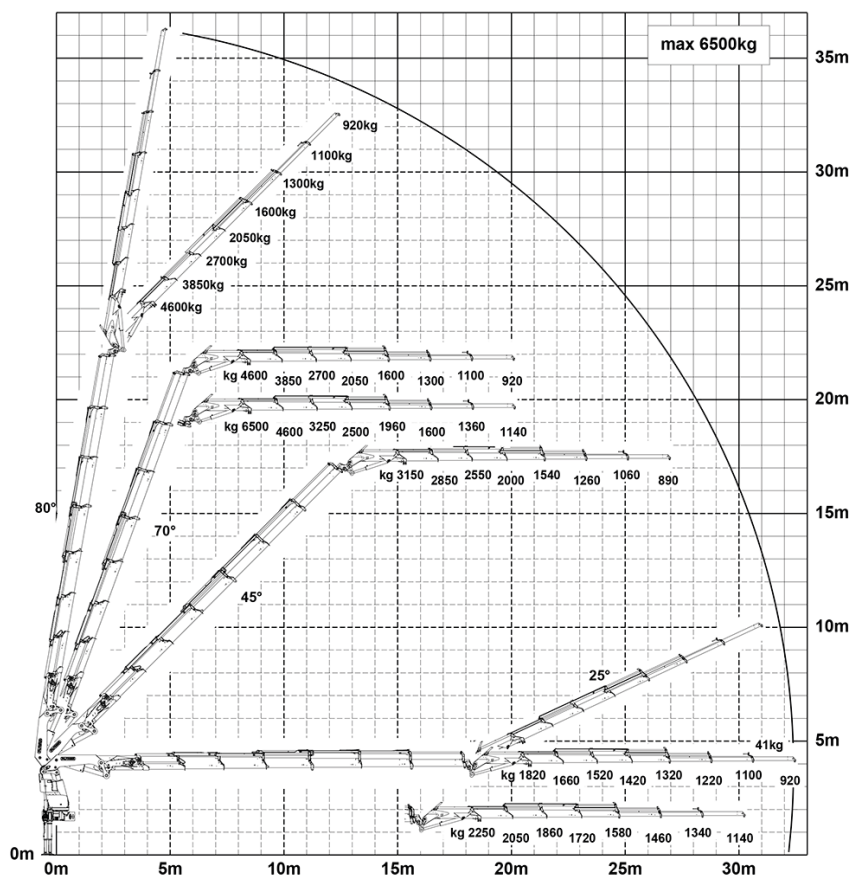

◆ 230 TN MOBILINOSTURI

60000 KG	8094 MM	4000 MM
15600 MM	111 M	2550 MM

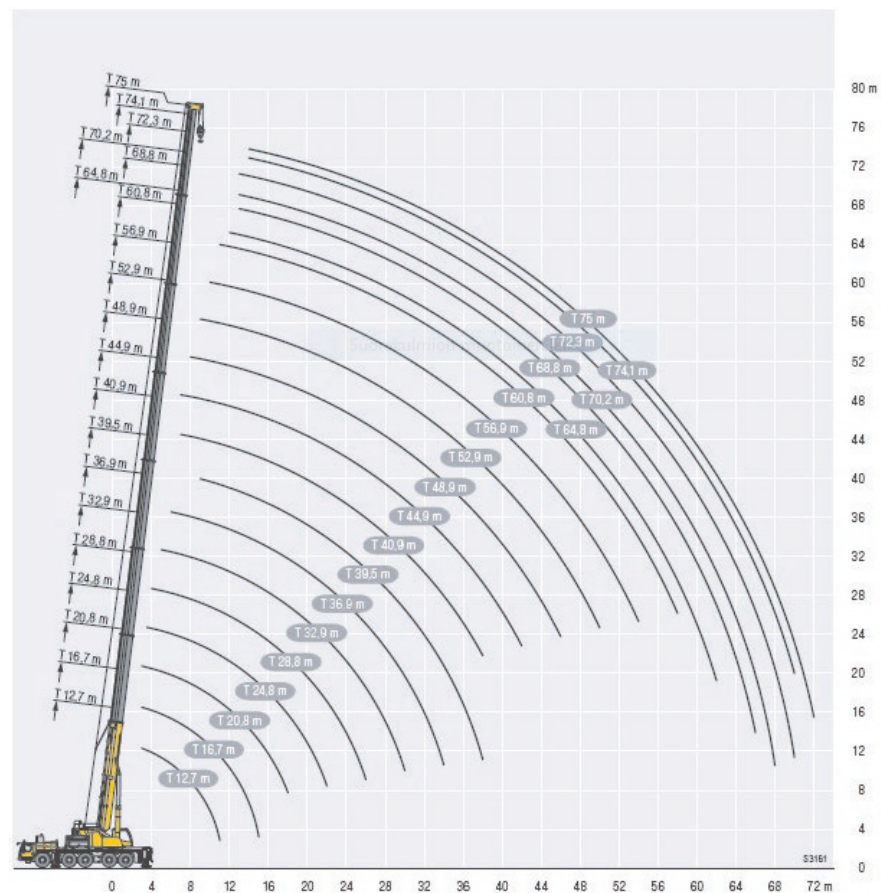
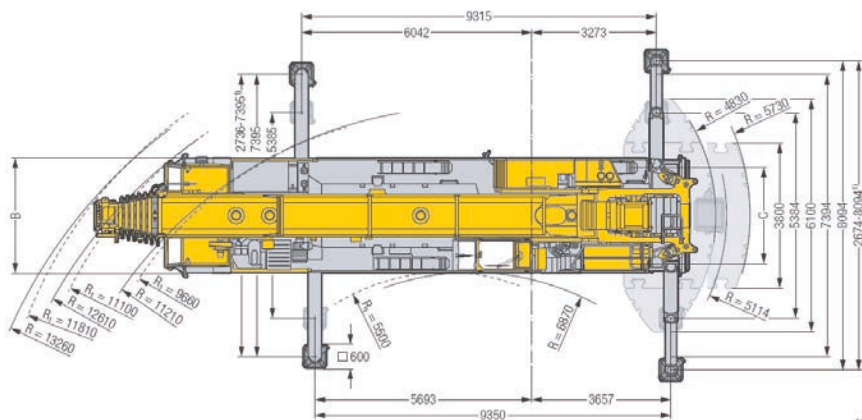
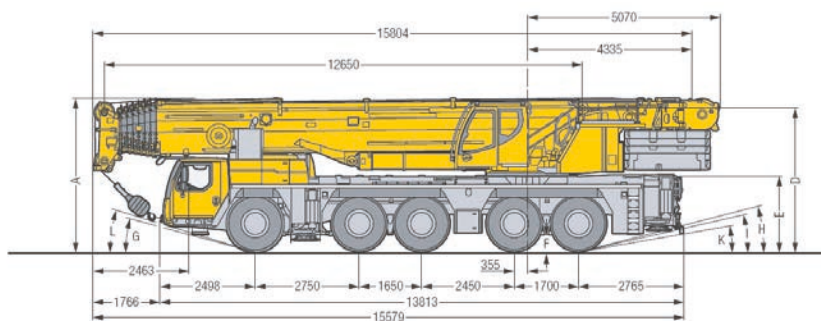

230 TN MOBILINOSTURI

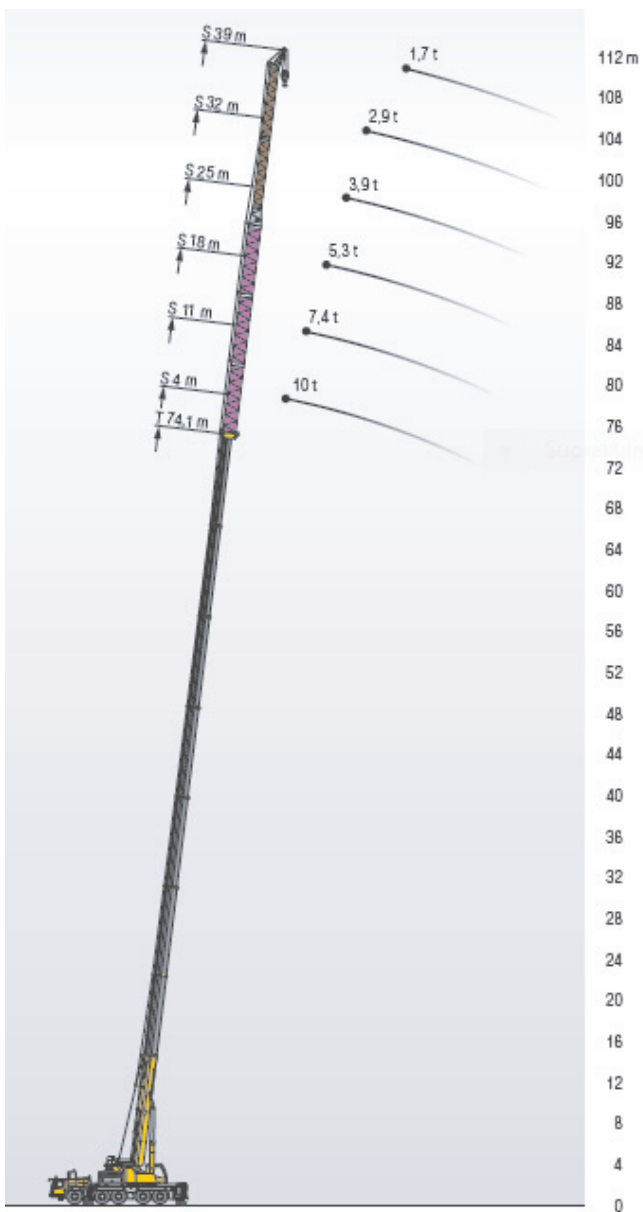

	12,7 m	16,7 m	20,8 m	24,8 m	28,8 m	32,9 m	36,9 m	40,9 m	44,9 m	
3	230	134	122,1	121,4						3
3,6	145,8	134	123,1	122	121,2					3,6
4	138,5	130,8	124,2	122,8	121,8					4
4,5	131,8	122,4	121,7	121,4	117,1	106,3				4,5
5	122,8	114,9	111,7	113,2	108,8	102,2	91,1			5
6	107,5	101,4	101,7	99,4	95,7	90,9	86,9	80		6
7	95,5	90,6	91,2	89,6	86,8	82,9	79,6	75,6	66,5	7
8	85,3	81,5	82,3	80,7	79,2	76	72,5	69,3	65,3	8
9	76	73,7	74,7	73,3	71,9	69,5	66,2	64	61,3	9
10	66,4	66,4	66,1	67,1	65,9	64	61	59,4	56,8	10
11	52,6	52,6	52,2	51,0	50,0	49	46,5	44,1	42,7	11
12			47,1	46,3	45,3	44,5	44,1	42,7	40,6	12
13			44,3	44,3	43,5	42,7	42,7	40,6	38,6	13
14			40,9	41,6	41,3	41,5	40,2	38,4	36,6	14
15			34,5	34,5	34,5	34,5	33,6	31,4	29,6	15
16				31,3	31,9	31,6	31,1	30,3	28,6	16
18				26,4	27,4	27,4	27,4	26,6	24,3	18
20					25,1	24,7	24,1	23,4	22,1	20
22					21,4	21,4	20,6	20,4	19,3	22
24						19,6	19	18,3	18,9	24
26							17	17,3	17	26
28							15,4	16	15,2	28
30								14,5	13,7	30
32								13,2	12,4	32
34								11,4	11,3	34
36									10,7	36
38									9,6	38
40										40
42										42

	48,9 m	52,9 m	56,9 m	60,8 m	64,8 m	68,8 m	69,7 m	72,3 m	74,1 m	75 m	
8	39,2										8
9	42,1	34,9									9
10	40	34	28,8								10
11	38	32,9	28,3	23,8							11
12	36,1	31,9	27,4	23,5	19,7						12
13	34,2	30,8	26,4	22,8	19,5	16,4	15,3	12,5			13
14	32,6	28,7	25,5	22,1	19,2	16,2	15,6	12,7	12		14
15	31,1	28,4	24,6	21,4	18,8	15,9	15,4	12,6	11,9	11,7	15
16	29,7	27,2	23,7	20,7	18,2	15,6	15,1	12,3	11,7	11,4	16
18	27,2	25,1	22,1	19,4	17,2	14,9	14,4	11,9	11,3	11	18
20	25,3	23,2	20,7	18,2	16,2	14,3	13,8	11,4	10,8	10,6	20
22	23,5	21,5	19,4	17,1	15,3	13,6	13,2	10,9	10,4	10,2	22
24	21,7	19,9	18,1	16,1	14,5	12,9	12,6	10,4	9,9	9,7	24
26	19,8	18,6	16,9	15,1	13,7	12,3	12	9,9	9,4	9,3	26
28	18,3	17	15,7	14,1	12,9	11,6	11,3	9,5	8,9	8,8	28
30	16,3	15,7	14,6	13,3	12,1	10,9	10,7	9	8,4	8,3	30
32	14,9	14,3	13,8	12,4	11,4	10,3	10,1	8,6	7,9	7,9	32
34	13,4	13,1	13	11,6	10,7	9,7	9,6	8,2	7,5	7,4	34
36	12,1	12,2	11,9	10,9	10,1	9,2	9,2	7,9	7,1	7	36
38	11,4	11,4	10,8	10,2	9,5	8,6	8,5	7,5	6,7	6,6	38
40	10,7	10,4	9,7	9,6	9	8,2	8	7,2	6,3	6,2	40
42	9,8	9,4	8,8	8,8	8,5	7,7	7,6	6,9	5,9	5,8	42
44	9	8,6	8,2	8,1	8	7,3	7,2	6,6	5,6	5,4	44
46	7,6	8	7,9	7,7	7,5	6,9	6,8	6,3	5,3	5	46
48		7,7	7,7	7,1	6,9	6,5	6,5	6	5	4,7	48
50		6,6	6,6	6,6	6,3	6	6	5,7	4,7	4,4	50
52		6,6	6,3	6,3	5,7	5,4	5,5	5,4	4,4	4,1	52
54			5,8	5,8	5,3	4,9	5	5	4,2	3,9	54
56				5,3	4,9	4,4	4,5	4,5	4	3,6	56
58					4,3	4,5	4,1	4,2	3,8	3,4	58
60						4,2	3,7	3,8	3,6	3,2	60
62							3,4	3,5	3,4	3	62
64								3,1	3,2	3,1	64
66									2,8	2,7	66
68										2,4	68
70										2,1	70
72										1,5	72

150 TN MOBILINOSTURI

60000 KG	8094 MM	4000 MM
15600 MM	111 M	2550 MM

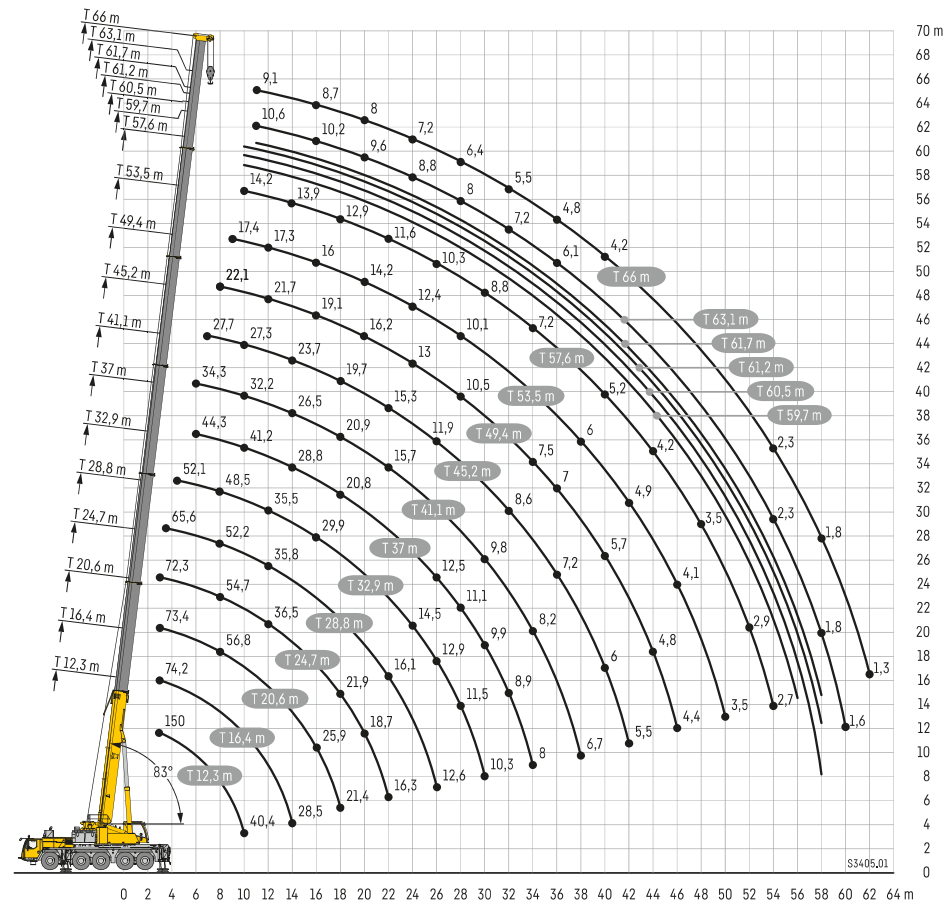
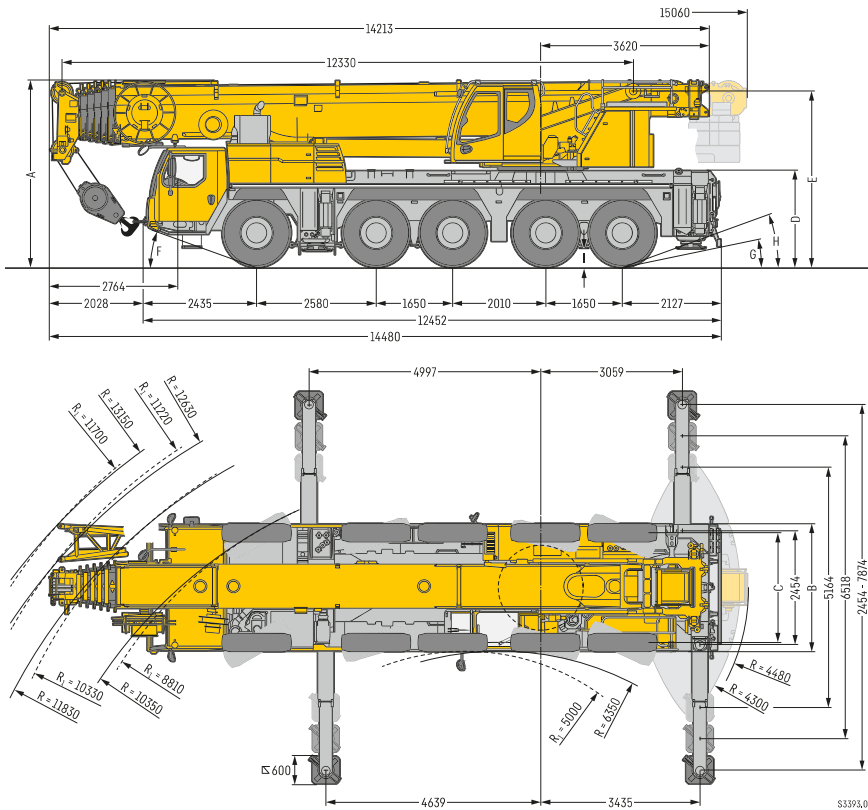

150 TN MOBILINOSTURI

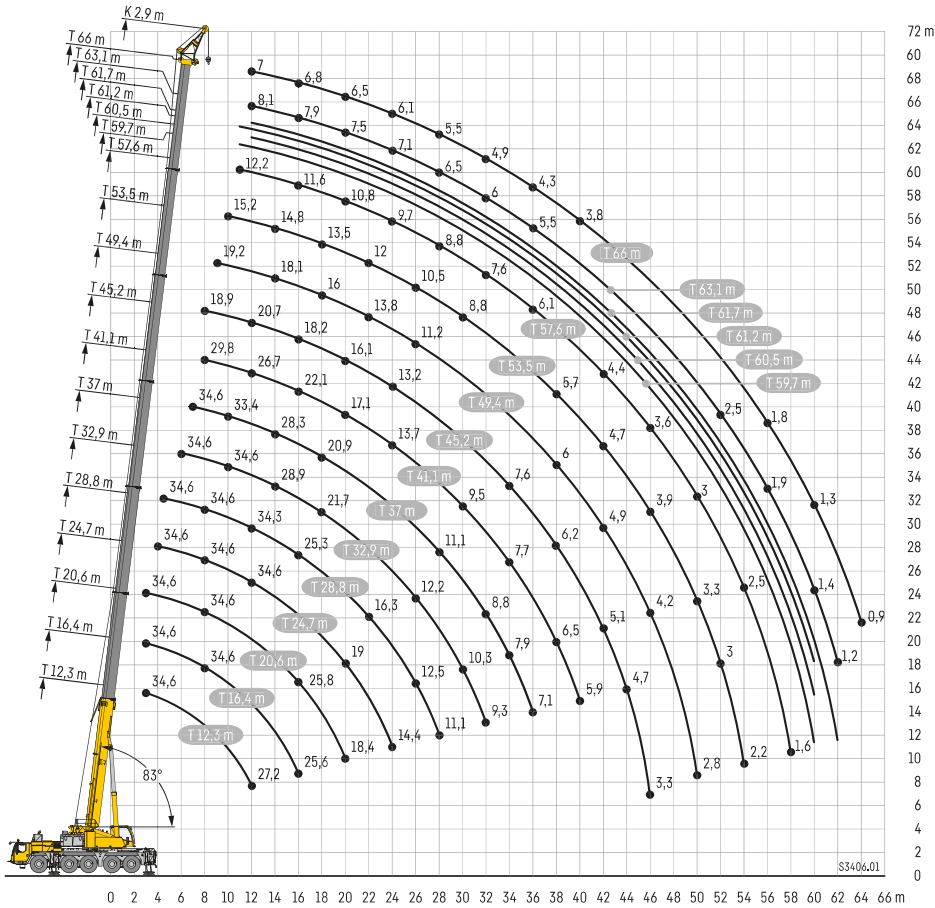

72 m
60
68
66
64
62
60
58
56
54
52
50
48
46
44
42
40
38
36
34
32
30
28
26
24
22
20
18
16
14
12
10
8
6
4
2
0



	32.3 m	34.4 m	36.6 m	38.8 m	41.1 m	43.4 m	45.7 m	48.0 m	50.3 m	52.6 m	54.9 m	57.2 m	59.5 m	61.8 m	64.1 m	66 m				
1	190	86	74.2	73.4	72.3											1				
3.5	111.3	86	74.2	73.4	72.3	65.5										3.5				
4	101.6	86	74.2	73.4	72.3	65.5										4				
4.5	92.8	85.7	74.2	73.4	72.3	65.5	52.1									4.5				
5	85.7	81.5	74.2	73.4	72.3	65.5	52.1									5				
6	75.9	71.3	71.3	69.1	66.2	63.4	52.1	44.3	34.3							6				
7	67	63.1	63.5	62.8	60.4	57.3	50.8	44.3	34.3	27.7						7				
8	57.4	56.5	56.7	56.8	54.7	52.2	45.5	44.3	34.2	27.7	22.1					8				
9	49.9	49.3	49.8	49.9	49.1	48	46.6	44	35.4	27.7	22.1	17.4				9				
10	40.4	40.5	44.3	44.7	44.6	43.6	42.8	41.2	32.2	27.3	23.1	17.4	14.2	12.5	12	10				
11			39.6	40	40.4	39.3	38.9	37.6	30.8	26.6	22	17.4	14.2	12.4	12	11				
12			35.7	36.1	36.5	35.8	35.5	34.3	29.3	25.7	21.7	17.3	14.2	12.3	11.8	11.4	10.6	9.1	12	
13			32.4	32.8	33.2	32.5	31.4	27.9	24.7	21.1	17.3	14.1	12.2	11.7	11.4	11.3	10.5	9	13	
14			28.5	30	30.4	30.4	29.9	28.8	26.5	23.7	20.5	16.8	13.9	12	11.6	11.2	10.4	8.9	14	
15			27.9	27.9	28	27.6	26.5	24.9	22.7	19.8	16.5	13.7	11.8	11.4	10.9	11.1	10.3	8.8	15	
16			25.9	25.8	25.9	25.4	24.4	23.2	21.7	19.1	16	13.5	11.6	11.2	10.6	11	10.2	8.7	16	
18			21.4	21.9	21.7	21.4	20.8	20.9	19.7	17.6	15.1	12.9	11.1	10.8	10.1	10.6	9.9	8.4	18	
20			18.7	18.6	18.1	18.5	18.2	17.3	16.2	14.2	12.3	10.5	10.3	9.5	10.2	9.6	8	20		
22			16.3	16.1	16.2	16.2	15.7	15.3	14.7	13.2	11.6	9.9	9.7	8.9	9.8	9.2	7.6	22		
24			14	14.5	14.3	13.6	13.6	13.1	12.4	10.9	9.4	8.1	8.3	8.3	8.8	7.2	24			
26			12.4	12.9	12.5	12.1	11.9	11.8	11.5	10.5	8.9	8.5	7.7	8.8	8.4	6.8	26			
28			11.5	11.1	10.7	10.8	10.6	10.1	9.7	8.4	7.2	6.4	7.2	6.4	8	6.4	28			
30			10.3	9.9	9.8	9.7	9.3	9.1	8.8	7.5	6.8	6	7.5	6.8	6	7.6	5.9	30		
32			9.1	8.6	8.9	9.1	8.6	8.4	8.2	7.9	7.6	7	6.4	7.6	7.2	5.3	32			
34			8	8.2	7.8	7.5	7.4	7.2	6.9	6.6	5.9	6.9	6.9	6.9	5.2	34				
36			7.4	7.2	7	6.6	6.5	6.3	6	5.5	6.3	6	5.5	6.1	6.1	4.8	36			
38			6.7	6.5	6.3	6	5.8	5.9	5.4	5.1	5.4	5.4	5.4	5.4	4.5	38				
40			6	5.7	5.5	5.2	5.2	5	4.7	4.7	4.7	4.7	4.7	4.7	4.7	4.7	4.7	4.7	40	
42			5.5	5.3	4.9	4.6	4.7	4.5	4.4	4.2	4.3	4.3	4.3	4.3	4.3	4.3	4.3	4.3	4.3	42
44			4.8	4.5	4.2	4.2	4	4.2	3.8	3.9	3.7	3.4	3.5	3.5	3.5	3.5	3.5	3.5	3.5	44
46			4.4	4.1	3.8	3.9	3.7	3.8	3.5	3.7	3.8	3.8	3.8	3.8	3.8	3.8	3.8	3.8	3.8	46
48			4	3.8	3.5	3.8	3.8	3.8	3.8	3.8	3.8	3.8	3.8	3.8	3.8	3.8	3.8	3.8	3.8	48
50			3.5	3.2	3.2	3	3.2	2.8	2.9	2.9	2.9	2.9	2.9	2.9	2.9	2.9	2.9	2.9	2.9	50
52			2.9	2.9	2.8	2.9	2.6	2.6	2.6	2.6	2.6	2.6	2.6	2.6	2.6	2.6	2.6	2.6	2.6	52
54			2.7	2.7	2.5	2.7	2.3	2.3	2.3	2.3	2.3	2.3	2.3	2.3	2.3	2.3	2.3	2.3	2.3	54
56			2.5	2.5	2.3	2.5	2.1	2.1	2.1	2.1	2.1	2.1	2.1	2.1	2.1	2.1	2.1	2.1	2.1	56
58			2.1	2.2	1.6	2.2	1.7	1.8	1.8	1.8	1.8	1.8	1.8	1.8	1.8	1.8	1.8	1.8	1.8	58
60			1.6	1.6	1.5	1.6	1.5	1.5	1.5	1.5	1.5	1.5	1.5	1.5	1.5	1.5	1.5	1.5	1.5	60
62			1.3	1.3	1.3	1.3	1.3	1.3	1.3	1.3	1.3	1.3	1.3	1.3	1.3	1.3	1.3	1.3	1.3	62



	32.3 m	34.4 m	36.6 m	38.8 m	41.1 m	43.4 m	45.7 m	48.0 m	50.3 m	52.6 m	54.9 m	57.2 m	59.5 m	61.8 m	64.1 m	66 m								
1	34.6	34.6	34.6													1								
3.5	34.6	34.6	34.6													3.5								
4	34.6	34.6	34.6	34.6												4								
4.5	34.6	34.6	34.6	34.6	34.6											4.5								
5	34.6	34.6	34.6	34.6	34.6											5								
6	34.6	34.6	34.6	34.6	34.6	34.6										6								
7	34.5	34.6	34.6	34.6	34.6	34.6	34.6									7								
8	33.7	34.8	34.6	34.6	34.6	34.6	34.6	29.8	18.9							8								
9	32.3	34.5	34.6	34.6	34.6	34.6	34.6	34.5	22.2	19.2						9								
10	30.6	33.9	34.6	34.6	34.6	34.6	34.6	33.4	28.7	21.8	19.1	13.7	15.2			10								
11	29.1	33.1	34.5	34.6	34.6	34.6	34.6	32.2	27.8	21.3	19	13.5	15.2	12.2	11.4	10.1	12.2	10.8	11					
12	27.2	31.8	34	34.6	34.3	34.1	31	28.7	20.7	18.7	13.2	15.3	12	11.3	9.9	12.1	10.7	10.1	12					
14	22.4	30.2	30.3	29.8	28.9	28.9	28.4	18.1	12.8	16.8	11.8	10.8	9.8	11.1	10.4	9.1	11.6	10.3	14					
16	25.6	25.8	25.7	25.5	24.3	22.1	18.2	17.2	11.7	14.2	11.1	10.4	9.1	11.6	10.3	9.6	9.3	9.4	7.9	7.7	7	6.8	16	
18		21.6	21.7	22	21.7	20.9	19.7	17.1	16	10.9	13.5	10.9	9.9	8.6	11.3	9.7	9.3	9	9.2	7.7	7.5	6.8	7	18
20		18.4	19	18.8	18.4	17.9	17.1	16.1	14.9	10.1	12.8	9.9	9.5	8.2	10.8	9.3	8.9	8.5	8.9	7.5	7.4	6.6	6.5	20
22		16.5	16.3	15.9	15.3	15.1	13.8	14.7	9.3	9	7	10.3	8.9	8.6	8	8.6	7.3	7.1	6.4	6.3	5.7	5.4	5.3	22
24		14.4	14.2	13.8	13.3	13.7	13.2	12.8	8.6	11.2	8.1	8.5	7.2	9.7	8.4	7.2	8.2	7.1	6.9	6.2	6.1	5.4	5.3	24
26			12.5	12.2	12.5	12	11.8	11.2	8.1	10.5	8.1	7.9	6.8	9.2	7.9	7.7	7	7.8	6.8	6.6	6	5.8	5.6	26
28			11.1	11.1	11	10.3	10.3	9.9	7.5	9.8	7.2	7.5	6.4	8.8	7.5	7.2	6.5	7.4	6.5	6.2	5.9	5.5	5.4	28
30			9.3	8.8	8.4	8.2	6.6	7.8	6.7	6.3	5.5	7.6	6.7	6.3	5.7	6.7	6	5.5	5.9	4.9	5.2	4.9	4.7	30
32			7.9	7.7	7.6	7.4	6.2	7.1	6.4	5.9	5.3	6.7	6.4	6	5.3	6.4	5.8	5.2	4.9	4.6	4.6	4.6	4.6	32
34			7.1	7.2	6.8	6.6	5.9	6.3	6	5.5	4.7	6.1	5.9	5.6	5	5.9	5.5	4.9	4.6	4.5	4.5	4.5	4.5	34
36			6.5	6.2	6	5.5	5.7	5.6	5.1	4.4	5.4	5.2	5.1	4.6	5.2	5.3	4.8	4.4	4.1	3.8	4	4.1	3.8	36
38			5.9	5.7	5.4	5.2	5.1	5	4.8	4.1	5	4.9	4.5	4.5	4.6	4.7	4.6	4.2	3.8	4	4.1	3.8	3.6	38
40			5.3	4.9	4.8	4.7	4.6	4.4	3.8	4.4	4.5	4.5	4.3	4.1	4.1	4.2	4.2	4	3.6	4.2	4	3.6	3.4	40
42			4.7	4.5	4.3	4.3	4.1	3.6	4	4.1	3.9	3.8	3.7	3.8	3.8	3.8	3.8	3.8	3.8	3.8	3.8	3.8	3.8	42
44			3.3	3.2	3.2	3.1	2.8	3.3	3.2	3.4	3.4	3.4	3.4	3.4	3.4	3.4	3.4	3.4	3.4	3.4	3.4	3.4	3.4	44
46			2.8	2.8	2.8	2.8	2.8	2.8	2.8	2.8	2.8	2.8	2.8	2.8	2.8	2.8	2.8	2.8	2.8	2.8	2.8	2.8	2.8	46
48			2.2	2.2	2.2	2.2	2.2	2.2	2.2	2.2	2.2	2.2	2.2	2.2	2.2	2.2	2.2	2.2	2.2	2.2	2.2	2.2	2.2	48
50			1.6	1.6	1.6	1.6	1.6	1.6	1.6	1.6	1.6	1.6	1.6	1.6	1.6	1.6	1.6	1.6	1.6	1.6	1.6	1.6	1.6	50
52			1.2	1.2	1.2	1.2	1.2	1.2	1.2	1.2	1.2	1.2	1.2	1.2	1.2	1.2	1.2	1.2	1.2	1.2	1.2	1.2	1.2	52
54			0.9	0.9	0.9	0.9	0.9	0.9	0.9	0.9	0.9	0.9	0.9	0.9	0.9	0.9	0.9	0.9	0.9	0.9	0.9	0.9	0.9	54

◆ 95 TN MOBILINOSTURI

60000 KG	7000 MM	4000 MM
14000 MM	82 M	2750 MM

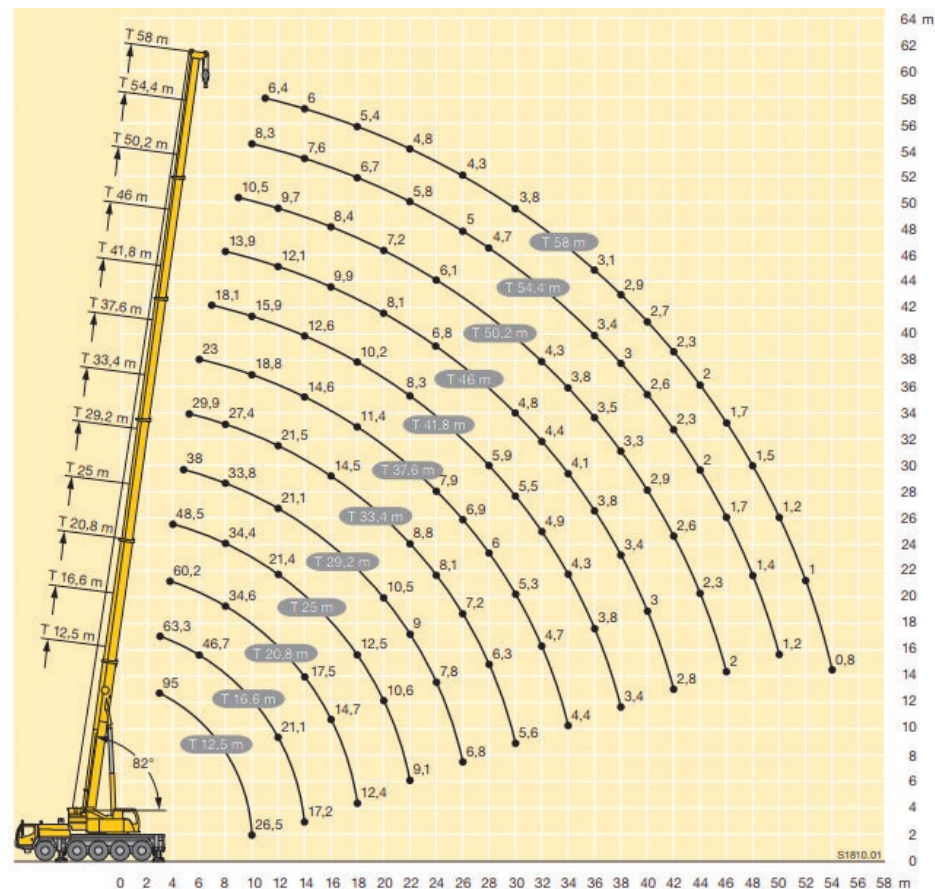
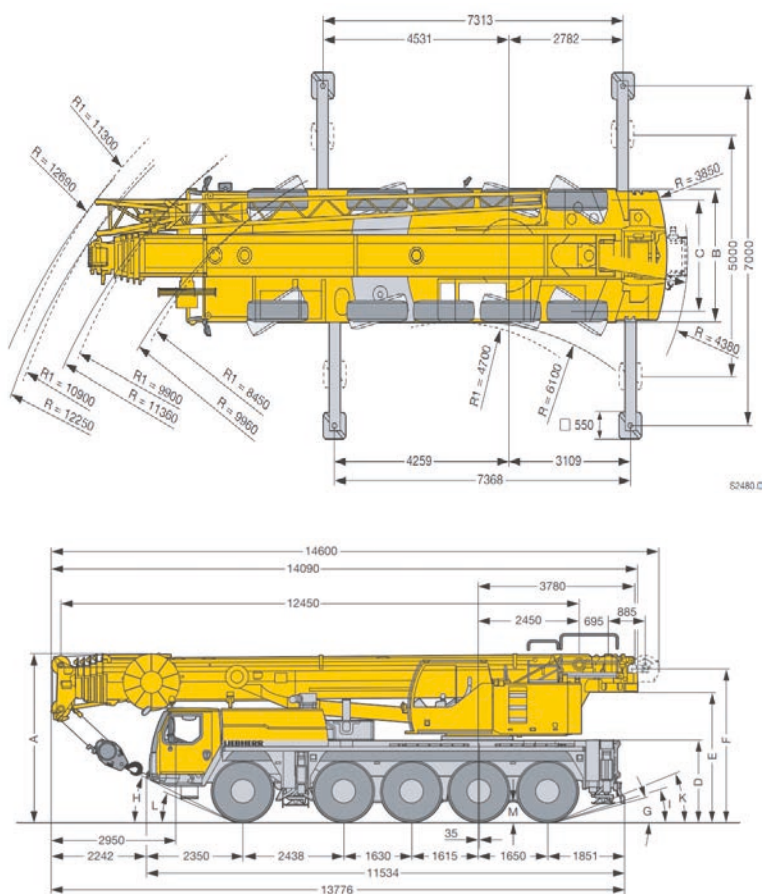

95 TN MOBILINOSTURI

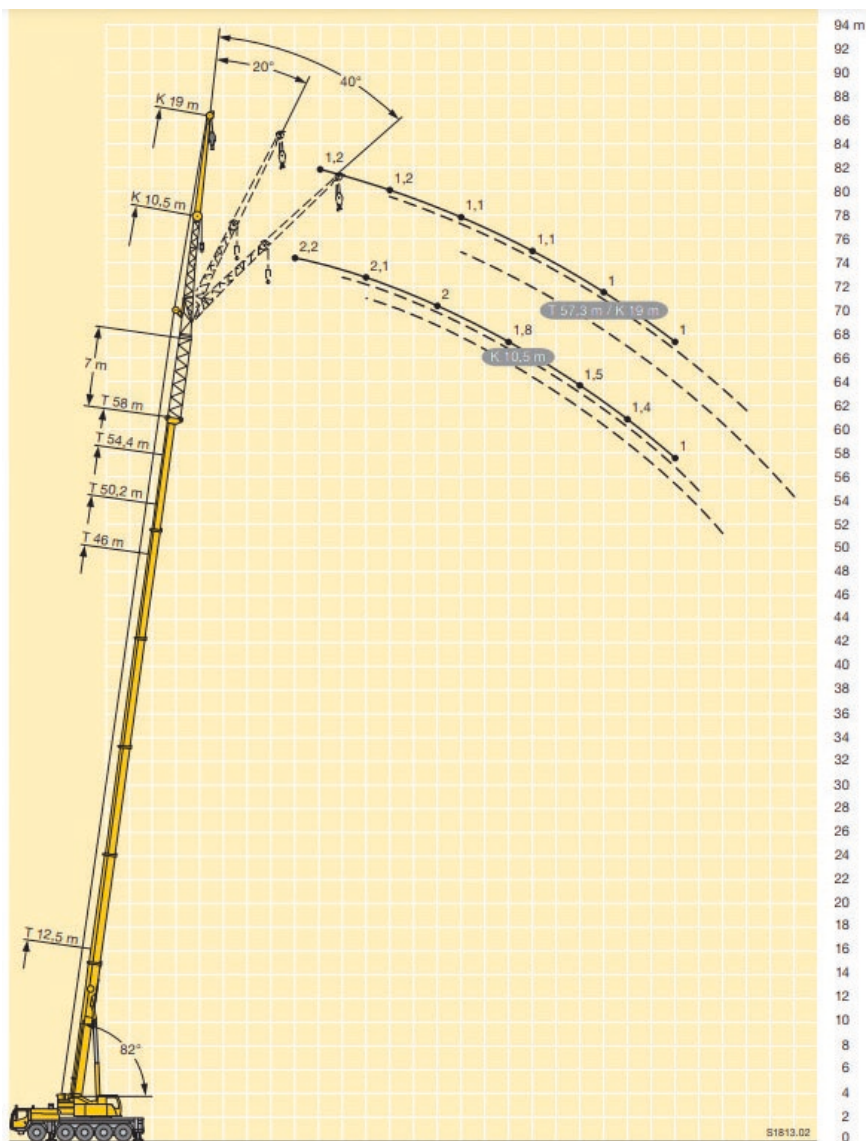

		12.5 - 58 m		360°		23 t		EN																	
		T		V		Z		EN																	
		12.5 m		16.6 m		20.8 m		25 m		29.2 m		33.4 m		37.6 m		41.8 m		46 m		50.2 m		54.4 m		58 m	
3	95	63.3	63.3																						3
3.5	74	63.3	63.3			60.2																			3.5
4	69.5	62.8	62.8			59.3	48.5																		4
4.5	66.3	59.1	58.9			55.9	47.9	38																	4.5
5	60.7	54.2	54.6			53.3	47.2	37.6	29.9																5
6	49.7	46.3	46.7			46.8	45.1	36.6	29.4	23															6
7	41.4	39.9	40.2			40.3	40.1	35.2	28.5	22.5															7
8	35.1	34.1	34.5			34.6	34.4	33.8	27.4	21.2															8
9	30.2	29.5	30.3			30	30.6	30.4	25.9	20															9
10	26.5	26	26.7			26.4	26.9	26.7	24.4	18.8															10
11			23.6			23.9	23.9	23.6	23.2	17.6															11
12			21.1			21.4	21.4	21.1	21.5	16.5															12
14			17.2			17.5	17.4	17.9	17.7	14.6															14
16						14.7	14.9	14.9	14.5	12.9															16
18						12.4	12.5	12.4	12.1	11.4															18
20							10.6	10.5	10.1	9.2															20
22							9.1	9	8.8	8.1															22
24									7.8	7.9															24
26									7.2	6.9															26
28									6.3	6															28
30									5.6	5.3															30
34										4.7															34
36										4.3															36
38										3.8															38
40										3.4															40
42										3															42
44										2.8															44
46										2															46
48										1.7															48
50										1.4															50
52										1.2															52
54										0.8															54

		12.5 - 57.3 m		7 m		19 m		360°		23 t		EN	
		T		V		Z		Z		Z		EN	
		12.5 m + 7 m		46 m + 7 m		50.2 m + 7 m		54.4 m + 7 m		57.3 m + 7 m			
		19 m		19 m		19 m		19 m		19 m			
		0°		20°		40°		0°		20°		40°	
4.5	2.1												4.5
5	2.1												5
6	2.1												6
7	2.1												7
8	2.1												8
9	2.1												9
10	2												10
11	2	1.9											11
12	2	1.9											12
14	1.8	1.9				2.1							14
16	1.7	1.8	1.7	2.1				1.8				1.6	16
18	1.5	1.7	1.7	2.1				1.8				1.6	18
20	1.4	1.5	1.6	2.1	1.9			1.8				1.6	20
22	1.3	1.4	1.5	2	1.9			1.8	1.8			1.6	22
24	1.2	1.2	1.4	2	1.9			1.8	1.8			1.6	24
26	1.1	1.1	1.2	1.9	1.8	1.7		1.8	1.8	1.7		1.6	26
28	1	1	1.1	1.9	1.8	1.7		1.8	1.7	1.7	1.6	1.5	28
30	0.9	0.8	0.9	1.8	1.7	1.7		1.7	1.6	1.6	1.5	1.1	30
32	0.8	0.7	0.8	1.7	1.6	1.6		1.7	1.6	1.6	1.5	1.1	32
34	0.7	0.7	0.7	1.6	1.6	1.6		1.6	1.5	1.5	1.5	1.1	34
36	0.6			1.5	1.5	1.5		1.5	1.5	1.5	1.5	1.1	36
38				1.4	1.4	1.4		1.4	1.4	1.4	1.4	1.1	38
40				1.3	1.3	1.3		1.4	1.4	1.4	1.3	1.1	40
42				1.3	1.3	1.3		1.3	1.3	1.3	1.3	1.1	42
44				1.2	1.2	1.2		1.2	1.2	1.2	1.2	1.1	44
46				1.1	1.1	1.2		1.2	1.2	1.2	1.2	1.1	46
48				1	1.1	1.1		1.1	1.1	1.1	1.1	1	48
50				1	1	1		1	1	1.1	1.1	0.9	50



PRIMUS, 8 T/M MININOSTURI

3350 KG	3305 MM	18,2 M	2100 MM
2640 MM		19 M	1200 MM

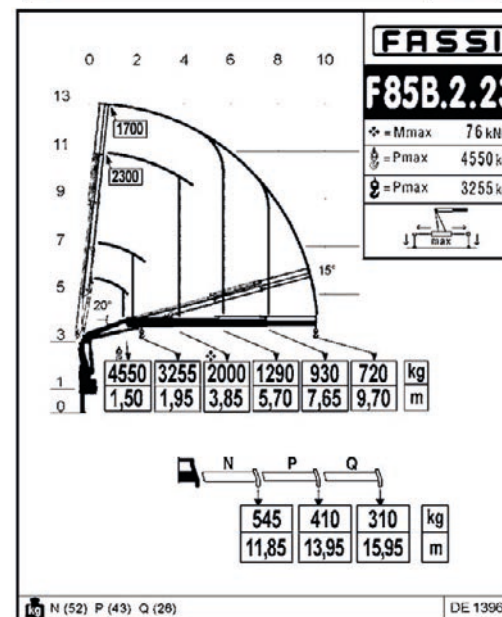
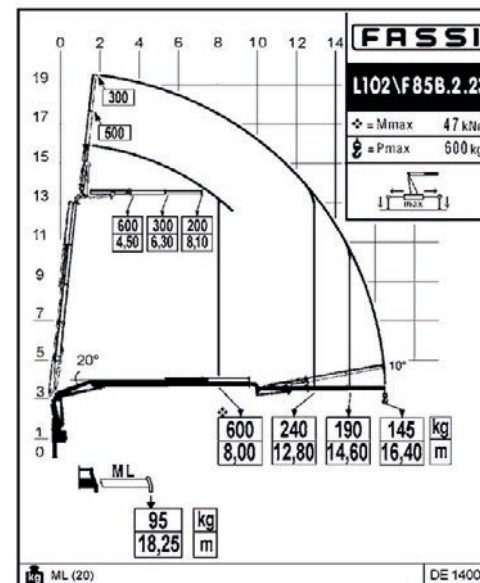

JEKKO JF990

28500 KG	8500 MM	38 M	3110 MM
6750 MM		41 M	2140 MM

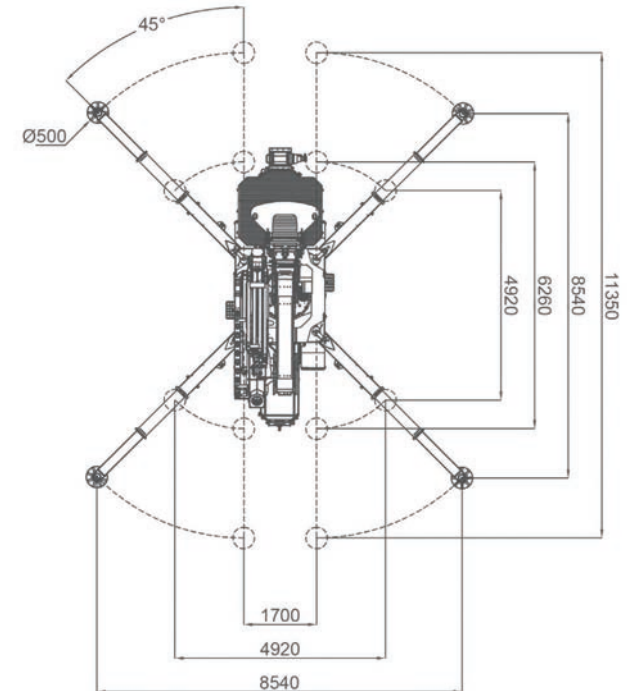
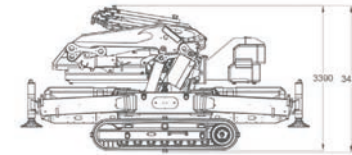
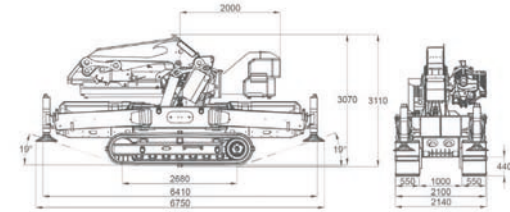
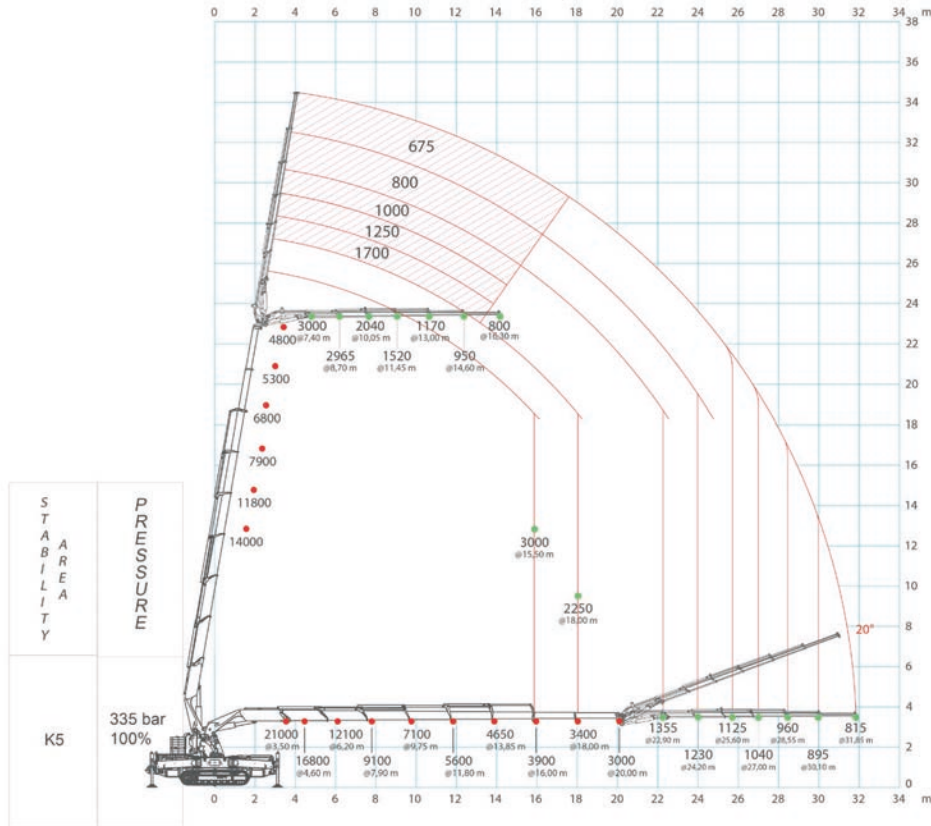

JEKKO JF545

17200 KG	6700 MM	28 M	2745 MM
5450 MM		30 M	1800 MM

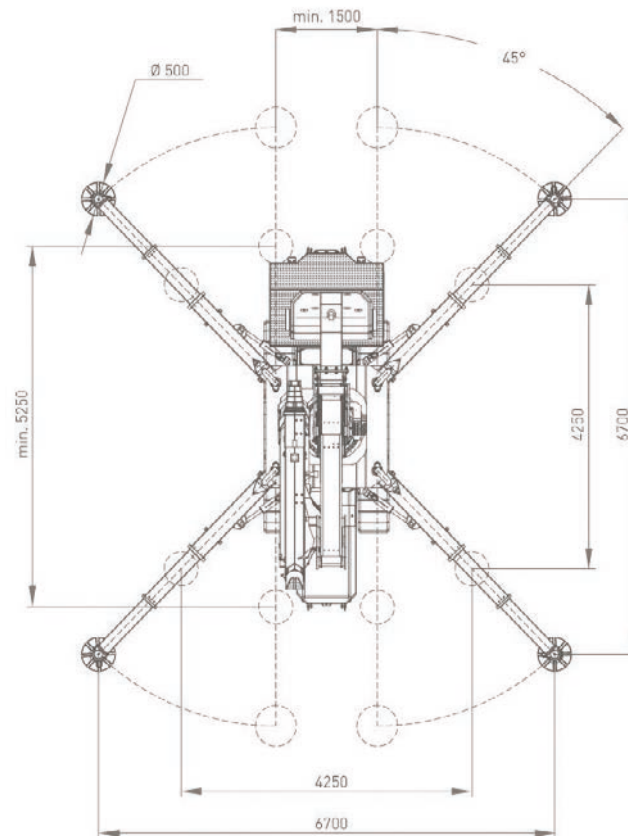
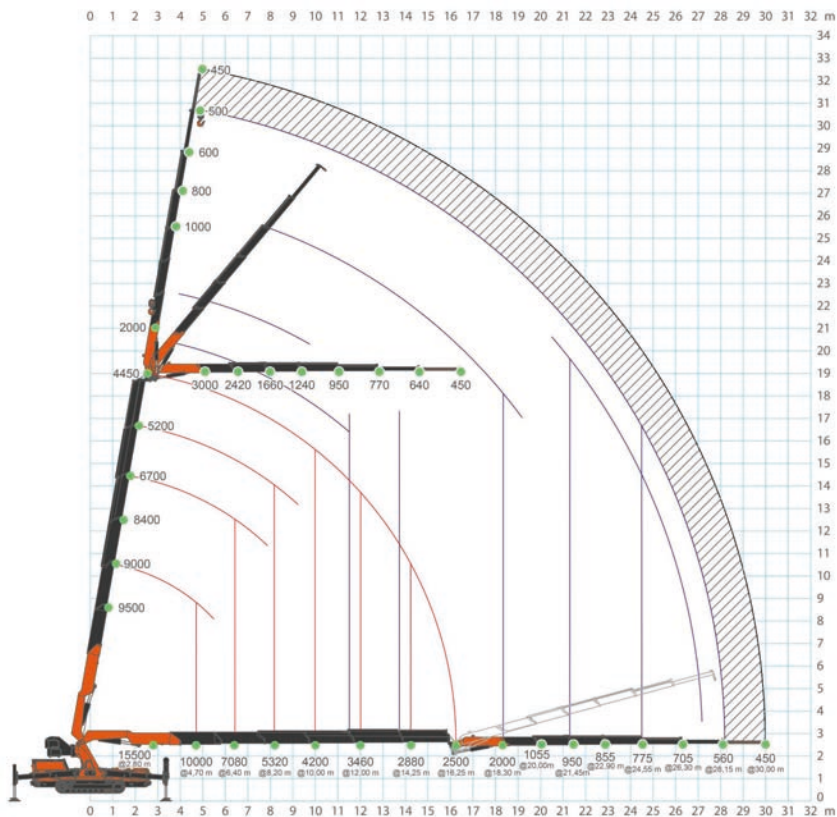
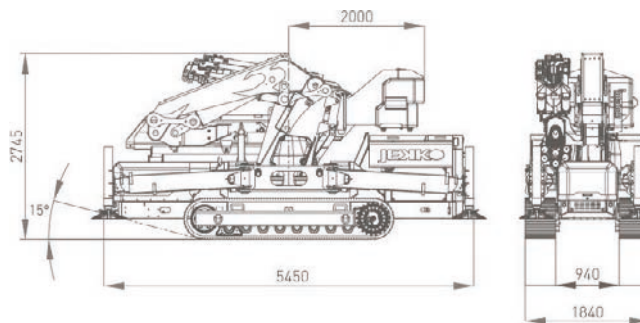





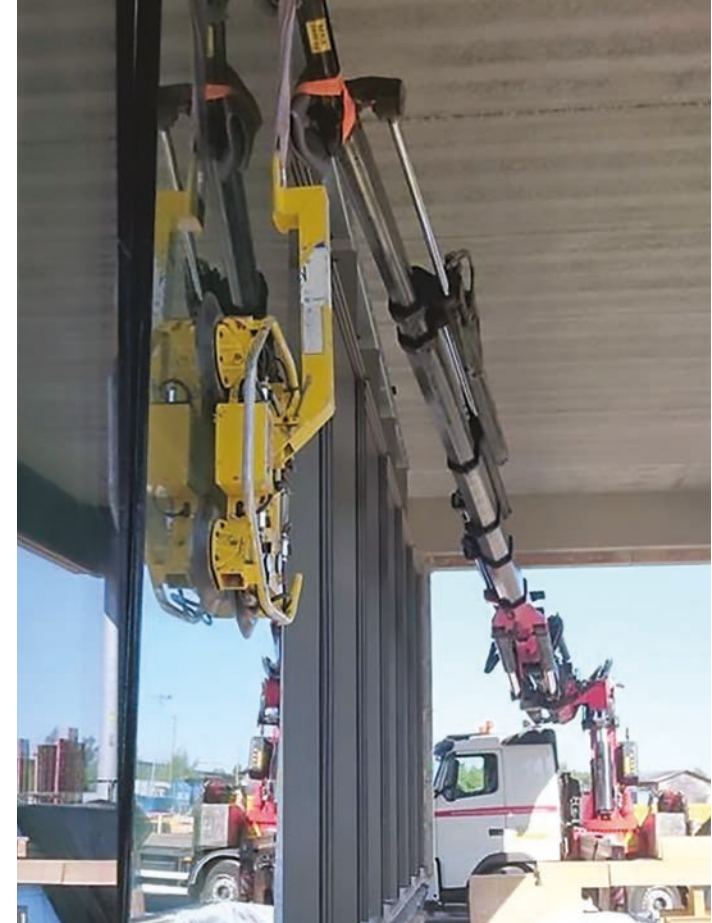

LISÄVARUSTEINA MM.

- PIENI HENKILÖKORI
- KELLUVA ISO KORI
- IMUKUPPI 450KG SAAKKA
- IMUKUPPI 450-1000KG
- KOURA
- ERILAISET NOSTOPALKIT (I-PALKKI, X-PALKKI)
- S-RAUTA / KOUKUN KOHOTTAJA
- KATTOTUOLIKOUKKU
- KAHTIILIHÄKKI
- LAVAHAARUKKA
- MEKAANISET KYLMÄT JATKOT
- JASSIKKA
- KÄÄNTÖPYÖRÄ
- C-RAUTA
- PALKKI / PUTKINOSTIN

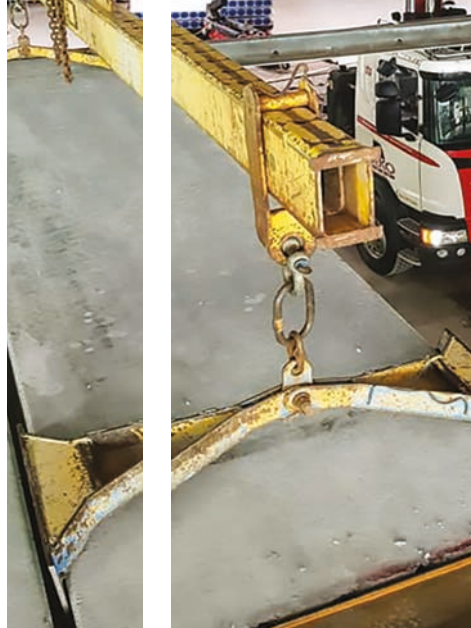



LUOTETTAVAA PALVELUA



VUODESTA 1961

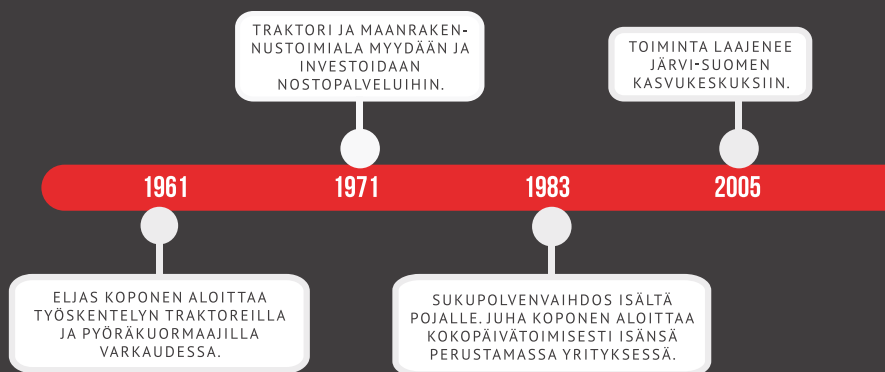

HANNU SEDIG
044 799 2103



KIMMO KOPONEN
040 844 5050



JUSSI TAMMENOJA
044 799 2102



TUOMAS PAARNIO
044 799 2109



VILLE KOIVISTO
044 799 2134



MIKKO HINTIKKA
040 079 9220



RAMI KOSKELA
044 799 2199



VELI-MATTI KIVINEN
0440 671 827



AKU KORHONEN
040 489 0313



SEPPÖ PUDAS
044 799 2166



◆ YMPÄRISTÖVASTUULLISUUS

Haluamme olla kestävä kehityksen edelläkävijä uusien toimintatapojen ja tuotteiden suunnittelussa. Kehittämämme toiminnot ja tuotteet vaikuttavat omalta osaltaan ympäristön hyvinvointiin ja turvallisuuteen.

Valmistamme ja kehitämme aktiivisesti korkealaatuisia ja ympäristöystävällisempiä tuotteita, sekä toimintatapoja. Haluamme varmistaa toiminnallamme kestävä ympäristön ja yhteiskunnan myös tuleville sukupolville.

Käytössämme/valikoimassa on myös nosturiautoja, joita voidaan käyttää sähköllä kun niihin liitetään Kurko Cranen valmistama sähköistysyksikkö.



OTA YHTEYTTÄ!

PÄÄKAUPUNKISEUTU

PUH. +358 44 799 2166

SAVO

PUH. +358 40 489 0313

JYVÄSKYLÄ

PUH. +358 44 799 2102

TAMPERE

PUH. +358 44 067 1827

LAPPEENRANTA

PUH. +358 44 799 2103

TURKU

PUH. +358 400 152 346

OULU

PUH. +358 40 665 2838

luotettava
kumppani



www.kurkokoponen.fi



**KURKO
KOPONEN**
NOSTOPALVELUIDEN ASIAANTUNTIJA